

Scope of Supply/Bill of Material & Mounting Drawings

Part Number: H-AFT18-01-01-SL / H-AFT18-01-02

Part Description: Head Light Guard –HONDA CRF1000L Africa Twin Adventure Sport

Applicable to Finished colour versions of Black and Silver

Installation / Parts List / Bill of Material for Mounting

No.	Description	Quantity	Torque * (N-m)	Remarks **
1	Head Light Guard	1		
2	Upper Bracket	1		
3	Lower Bracket	1		
4	Mounting Pin	4		
5	Grommet	4		
6	Screw M5 x 10	4	10	Use Liquid Thread Locker
7	Washer M5	4		

SRC Design uses Metric System of Measurement and all dimensions are in Millimeters

* Recommended to use the Torque specified in the table

** Denotes Usage of Liquid Thread Locker in specified locations

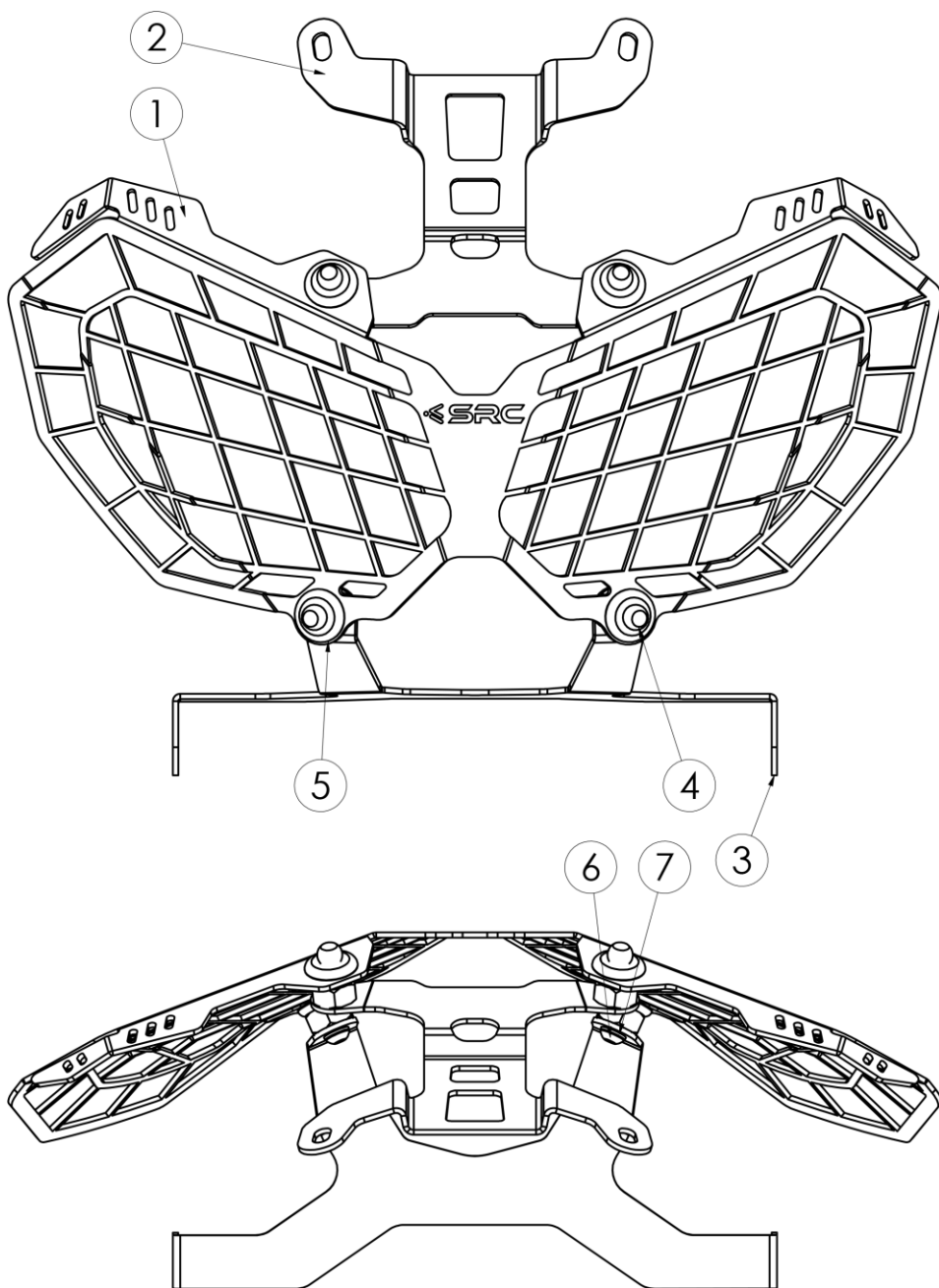

MOUNTING DRAWINGS

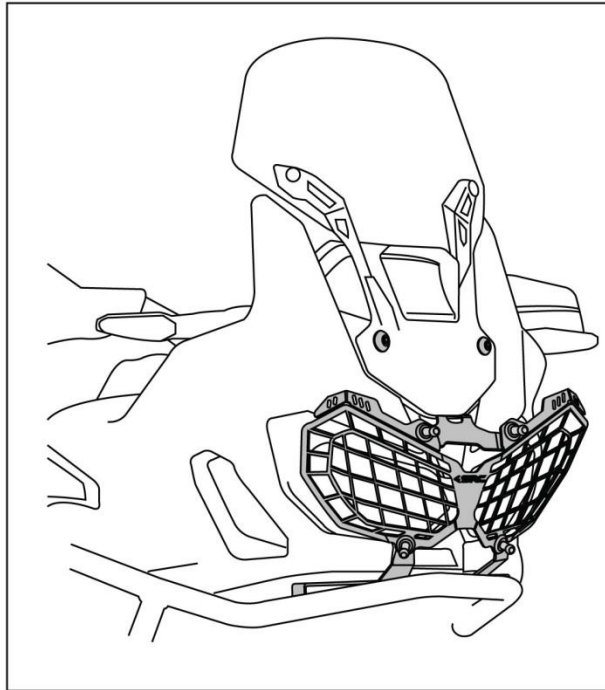
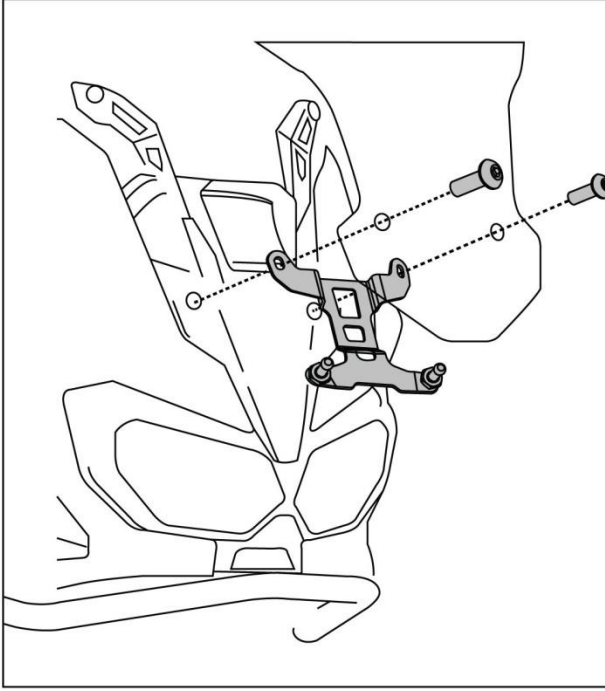
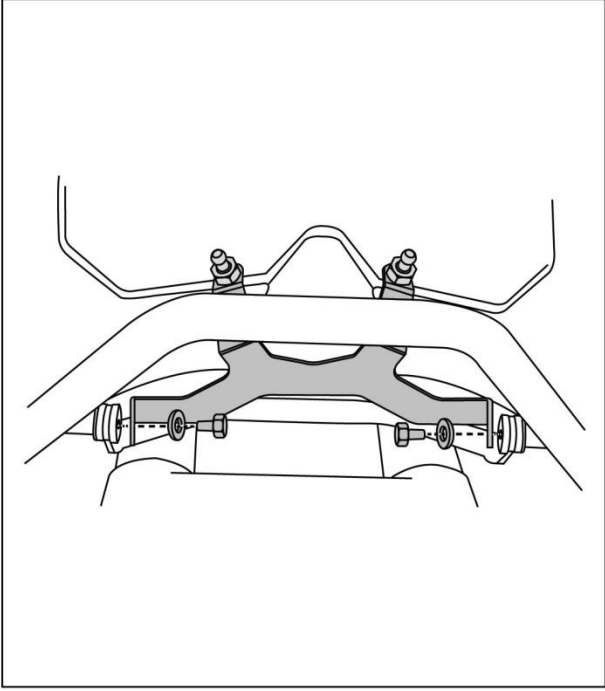
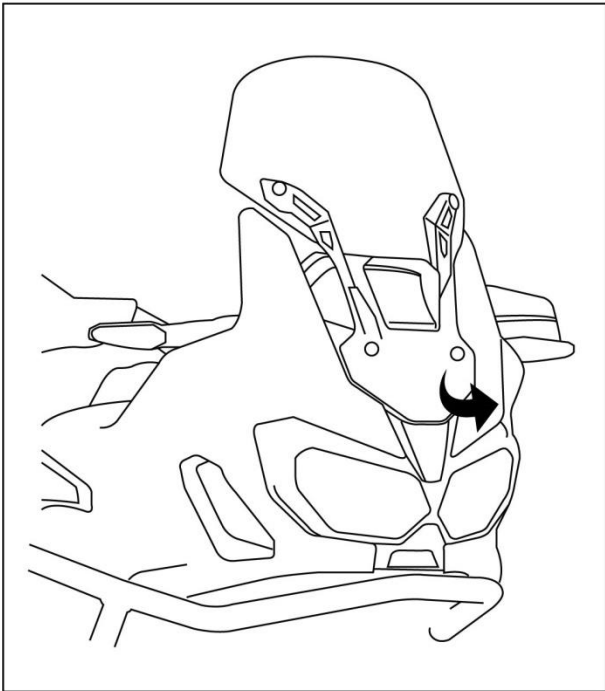

Mounting Instructions

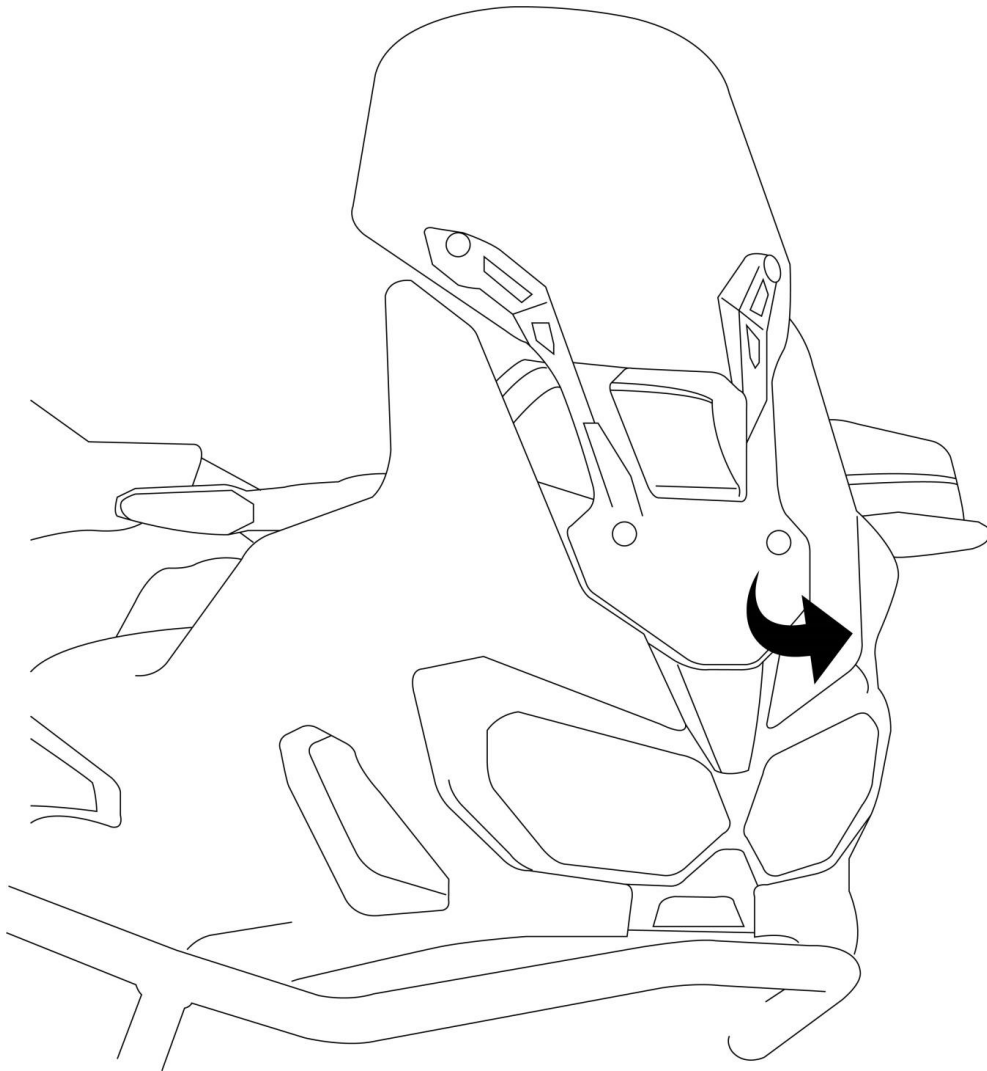

Step 1: Unscrew the two mounting screws of the Windshield Guard to enable access and fitment of the lower bracket (3)

Step 2: Orient and Align the Lower Bracket (3), as shown in the drawing, and slide in the Washer M5 (7) – 2 off and Screw M5 x 10 (6) – 2 off and secure the threads in the two ends to the Adaptor (which is already available in the Motorbike) and fully tighten them.

Slide in the Mounting Pin (4) – 2 off and Grommet (5) – 2 off as shown, in the lower bracket (This can be done off-line too)

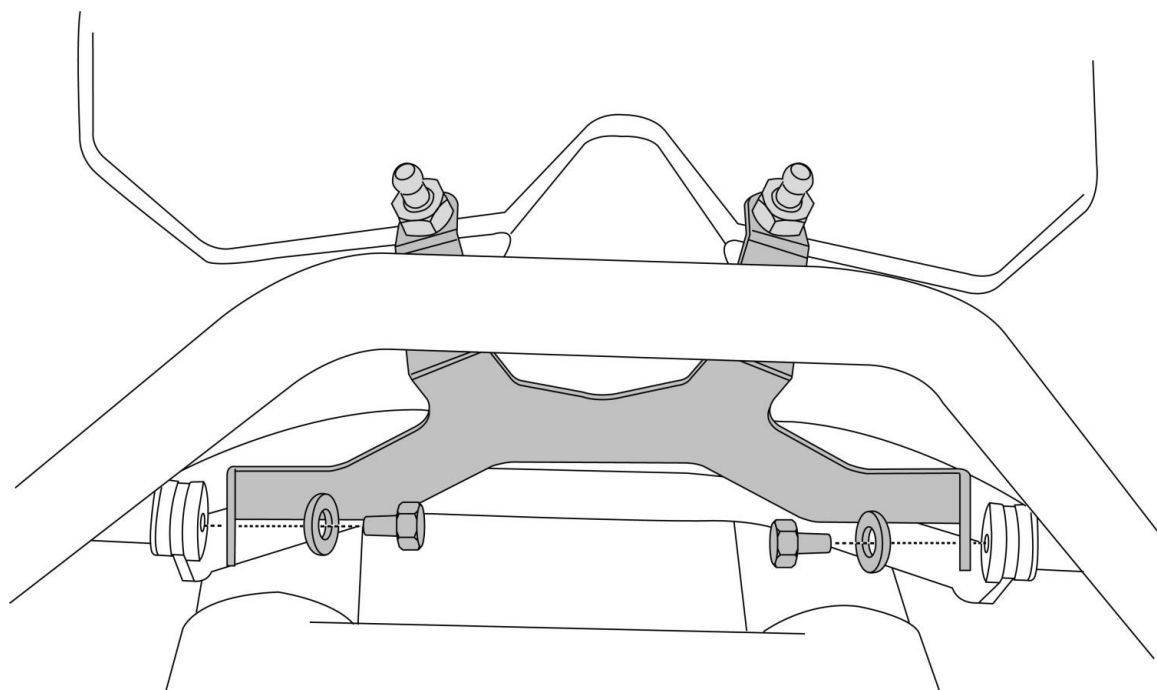

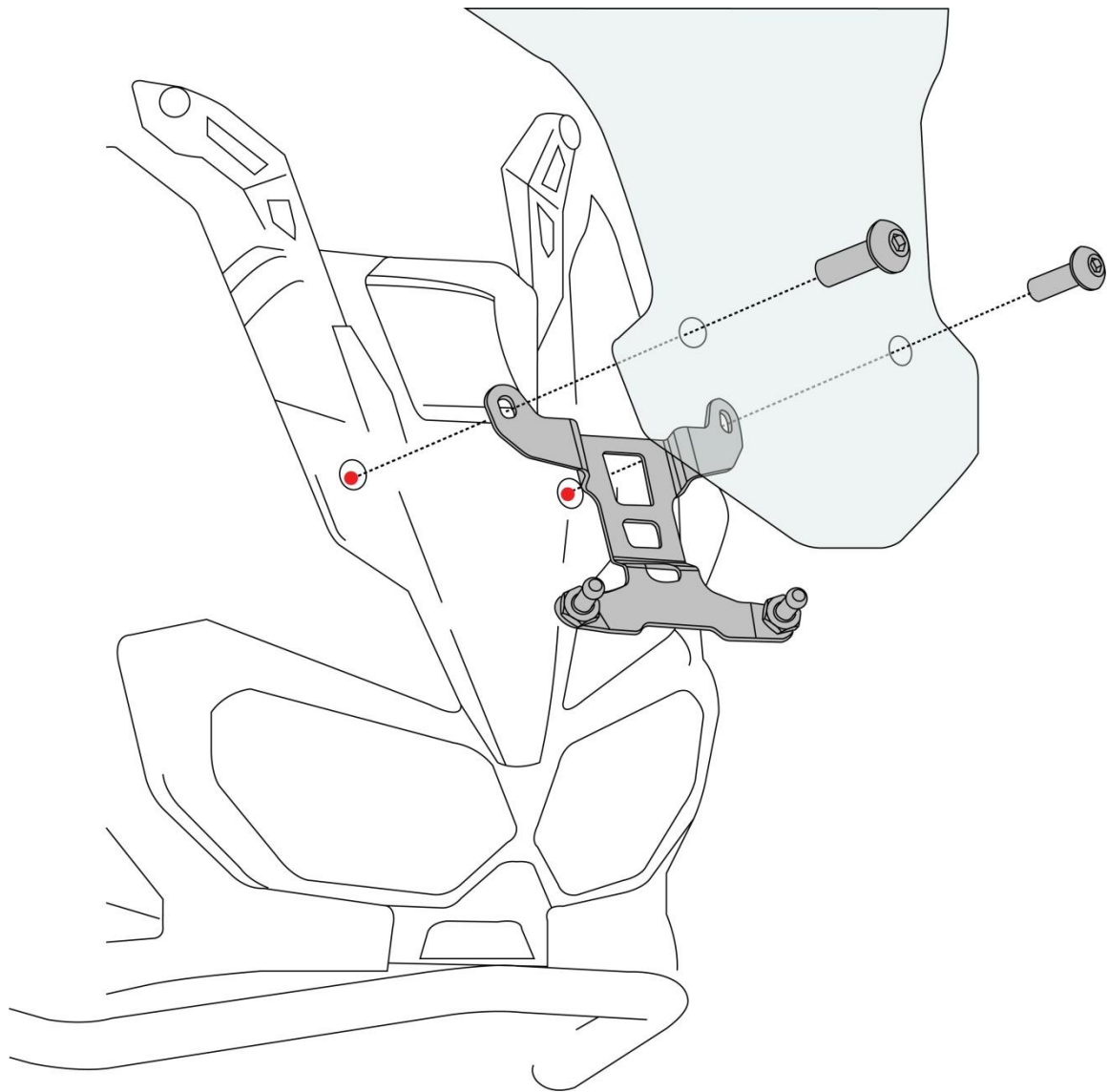

Step 3: Mounting the Upper Bracket (2) and the Windshield Guard (back in its position)

Orient and Align the Upper Bracket, as shown in the drawing, Slide in the Screws M5 x 10 – 2 off and washer (to be sandwiched between the Surface of the Upper Bracket Mounting hole and the lower side of the Windshield Guard).

Slide in the Mounting Pin (4) – 2 off and Grommet (5) – 2 off as shown, in the upper bracket (This can be done off-line too)

Step 4: Align the Head Light Guard (1) to the mounting pins (projecting out of the Lower and upper brackets) and secure the Annular groove in the grommet to the inner peripheral surface of the Head Light Guard.

Visually ensure the Orientation and position of the Head Light Guard

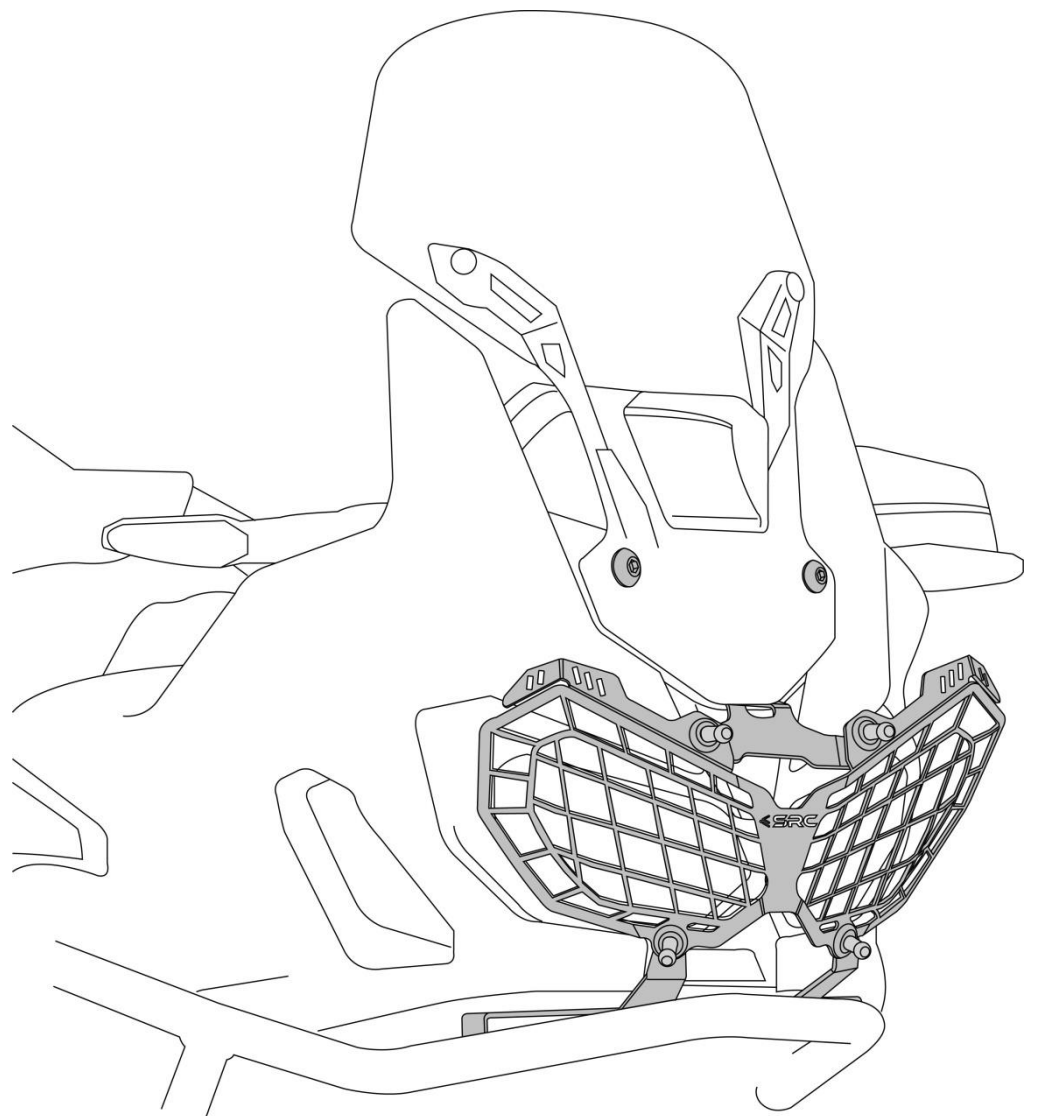



General Instructions

1. We request you to pay attention to the Mounting Instructions in this document and follow the step-by-step procedures.
2. This Mounting Instruction manual is a “Do It Yourself” (DIY) fitment manual of the Accessory part to the Vehicle. We have prepared this based on our experience and knowledge, related to the Vehicle, Part and its functional aspects.
3. SRC cannot guarantee the interchangeability of the parts to any other manufacturer’s accessory part. It is advised to the User, to inspect and ensure the original state of all other Vehicle parts.
4. We request you to bear in mind, that the Installed part can change the driving behaviour and/or the stability during driving or any other dynamic conditions.
5. If you have the appropriate tools and another person to assist you in the mounting, it will help.
6. After Completion of the Mounting and before taking on a First ride, Ensure and Check all functions of the Vehicle. It is always advised to check loosening of the fasteners after the first 50 kilo meters of ride and at regular intervals.
7. To the maximum extent possible, our design use the current Mounting/Fitment of the Original Equipment, so that Installation of these accessories will not affect the Payload or Function of the Vehicle or the Part on which it is mounted to protect it
8. If any additional modifications are to be done, prior to the fitment of the accessories, it will be explicitly specified in the instruction sheets