

## Scope of Supply/Bill of Material & Mounting Drawings

Part Number: Y-WR155-01-01-SL - Y-WR155-01-02

Part Description: Head Light Guard – YAMAHA WR155 R

### Installation / Parts List / Bill of Material for Mounting

NO.	Description	Quantity	Torque * (N-M)	Remarks **	Check List
1	Head Light Guard	1			
2	Bracket LH	1			
3	Mountinh Pin	2			
4	Screw M5 X 6	4	5 - 6	Use Liquid Thread Locker	
5	Washer M5	4			
6	Bracket RH	1			

SRC Design uses Metric System of Measurement and all dimensions in Millimeters

\* Recommended to use the Torque specified in the table

\*\* Denotes Usage of Liquid Thread Locker in specified Locations

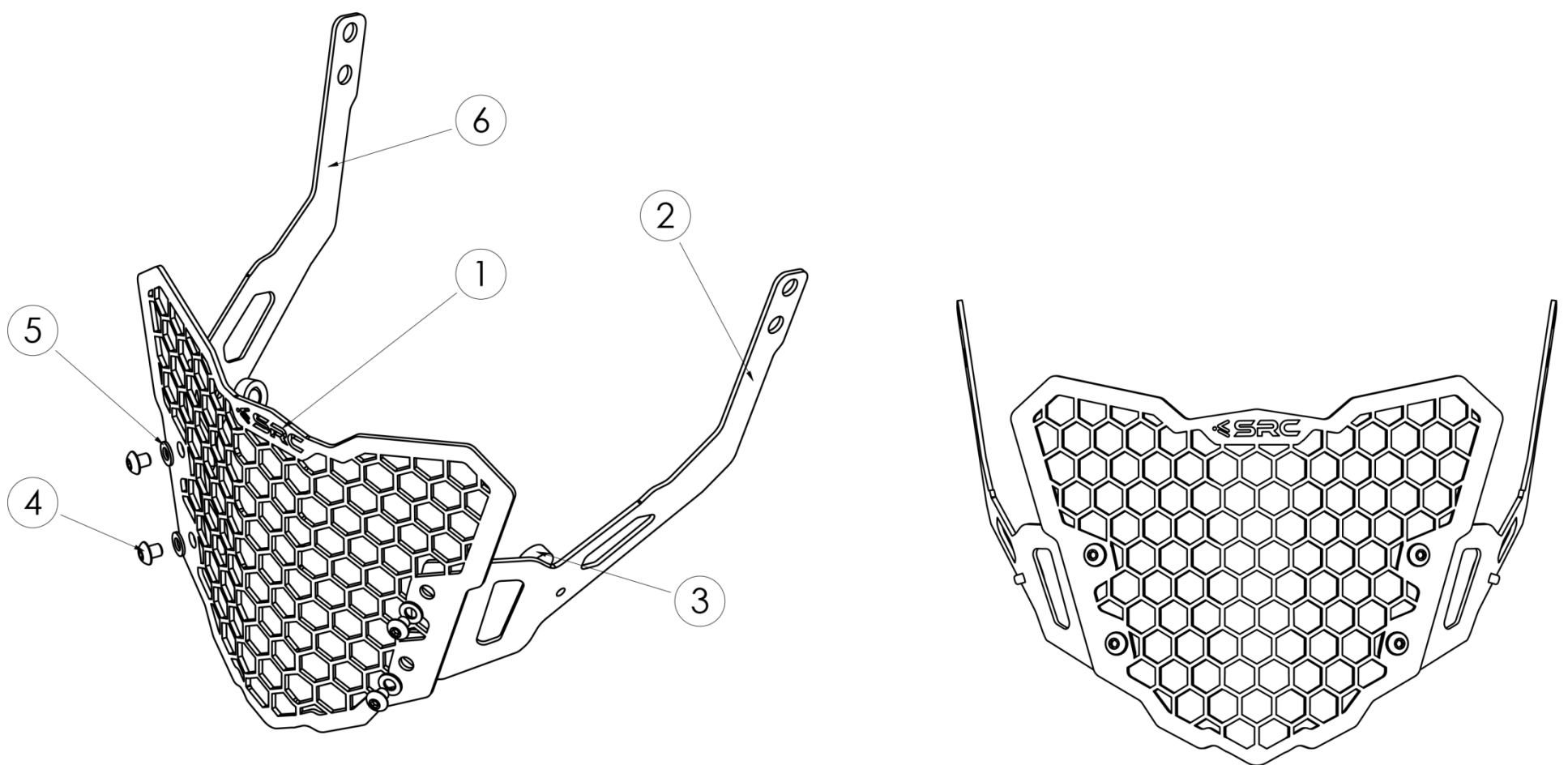

## MOUNTING DRAWINGS

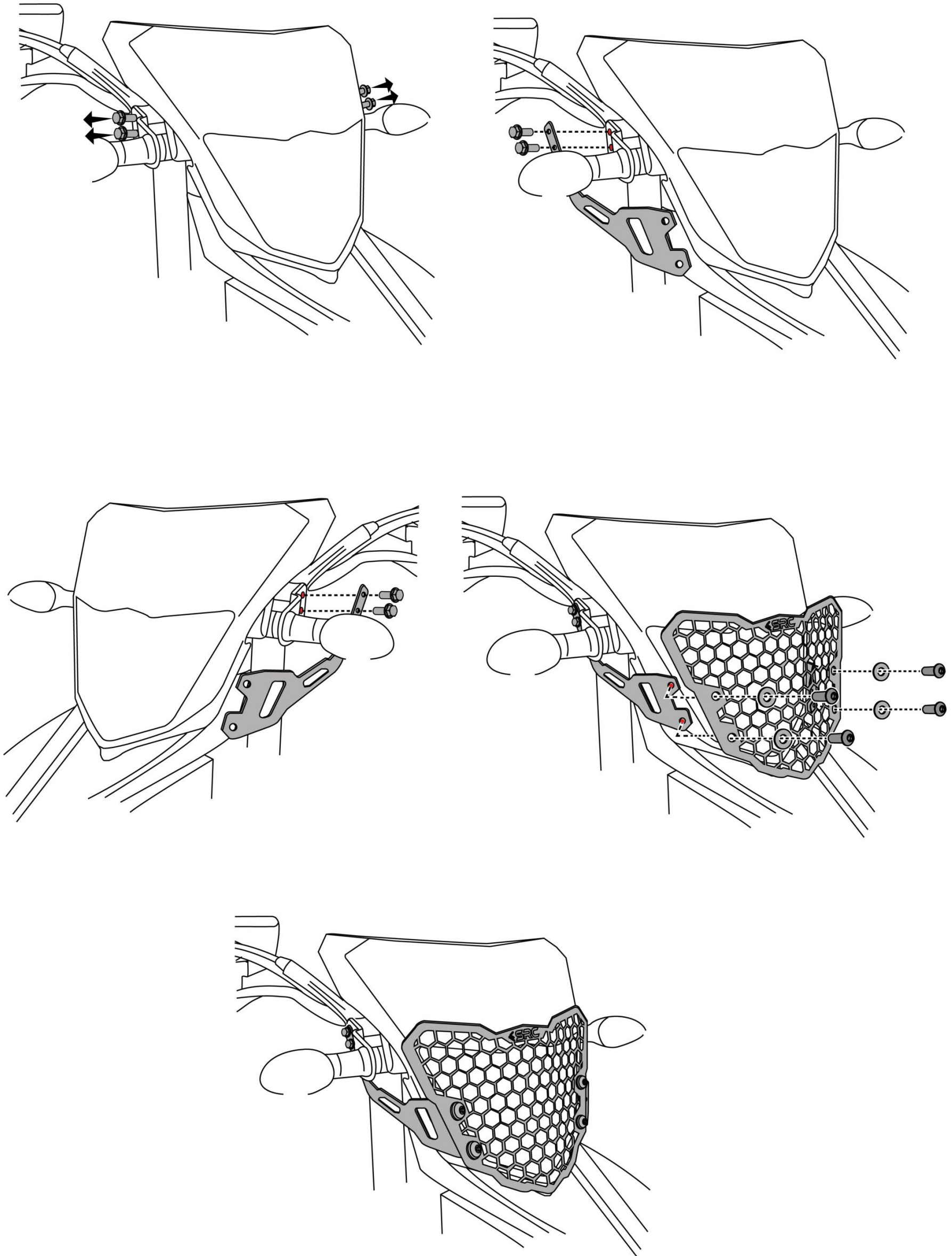

**Mounting Instructions**

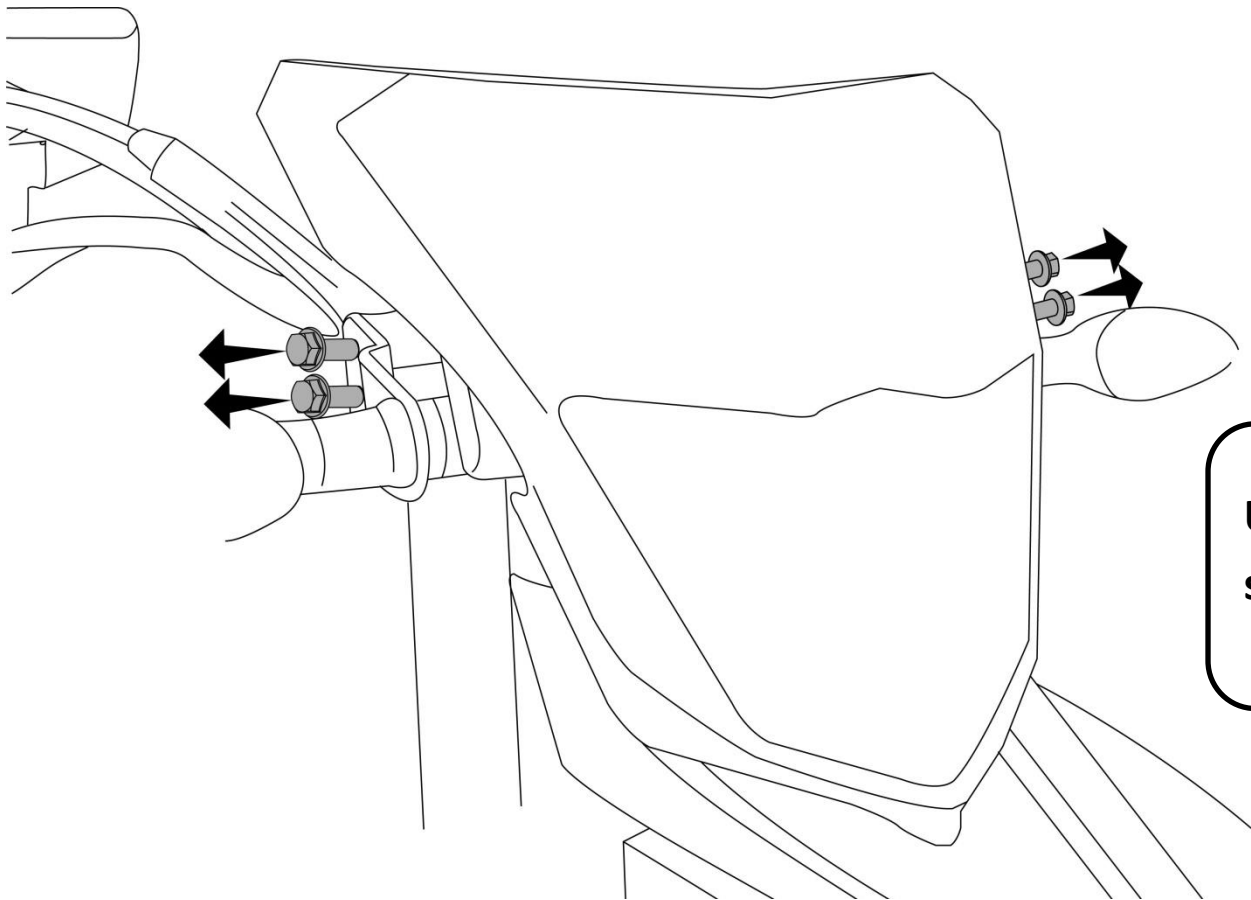

**Unscrew the mounting Original screws in side and remove.**

**STEP 1:**  
**Orient the Bracket RH (6), as shown, and slip-in the Original Screw in motobike and tighten it fully**

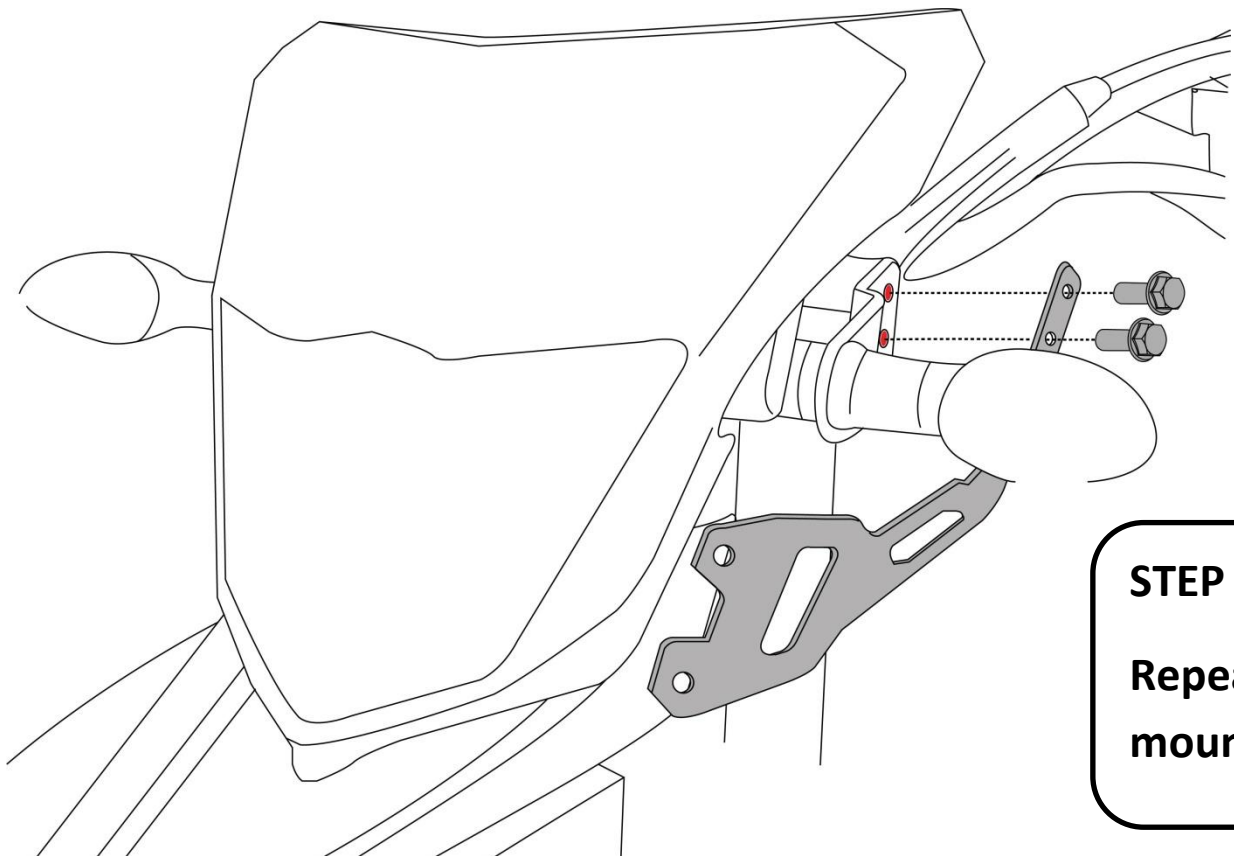
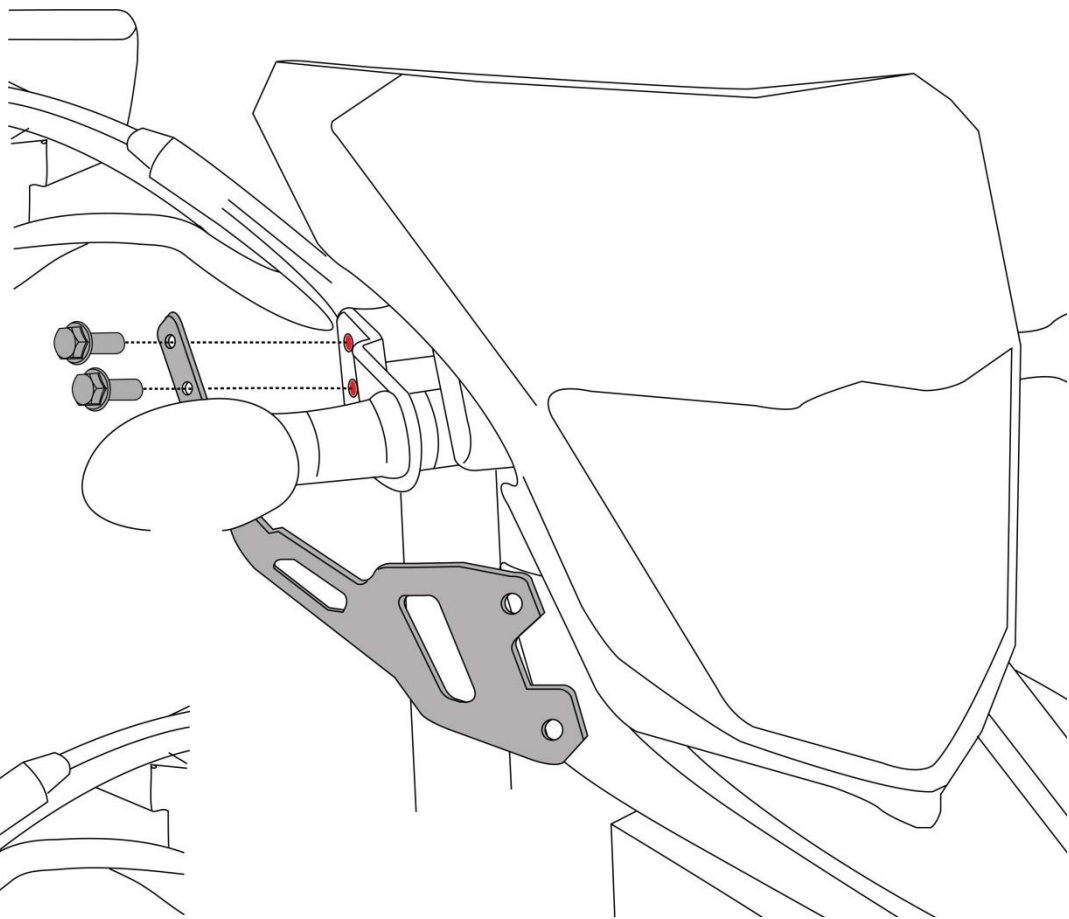

**STEP 2:**  
**Repeat the step on the Right Hand side, to mount the Bracket LH (2)**

**STEP 3:**

**Orient the Head Light Guard (1), as shown, to the Bracket RH&LH(2), (6) and slip-in the Washer M5 (5) and Screw M5x6 (4) – 4 off, and secure the threads, but not tighten it fully**

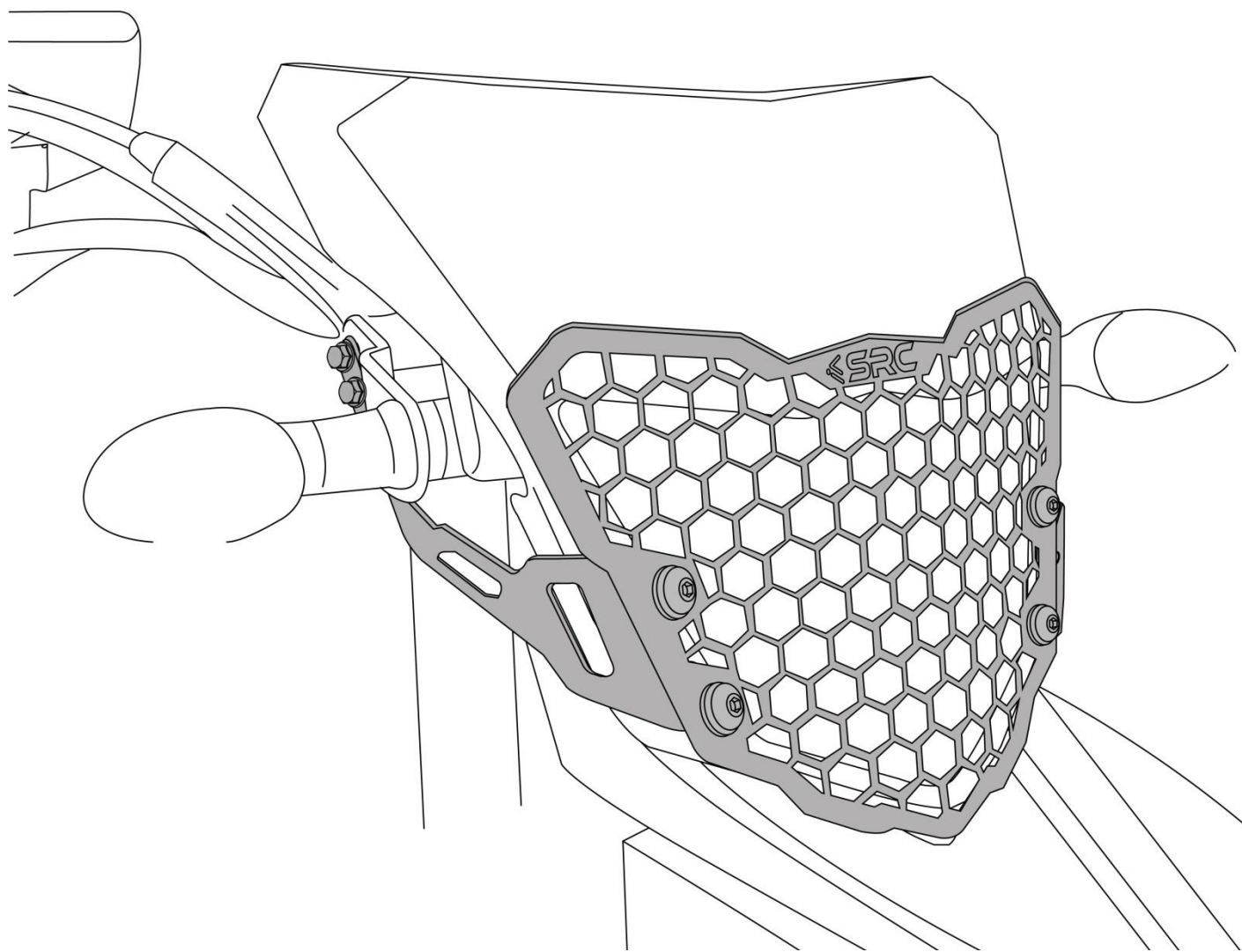
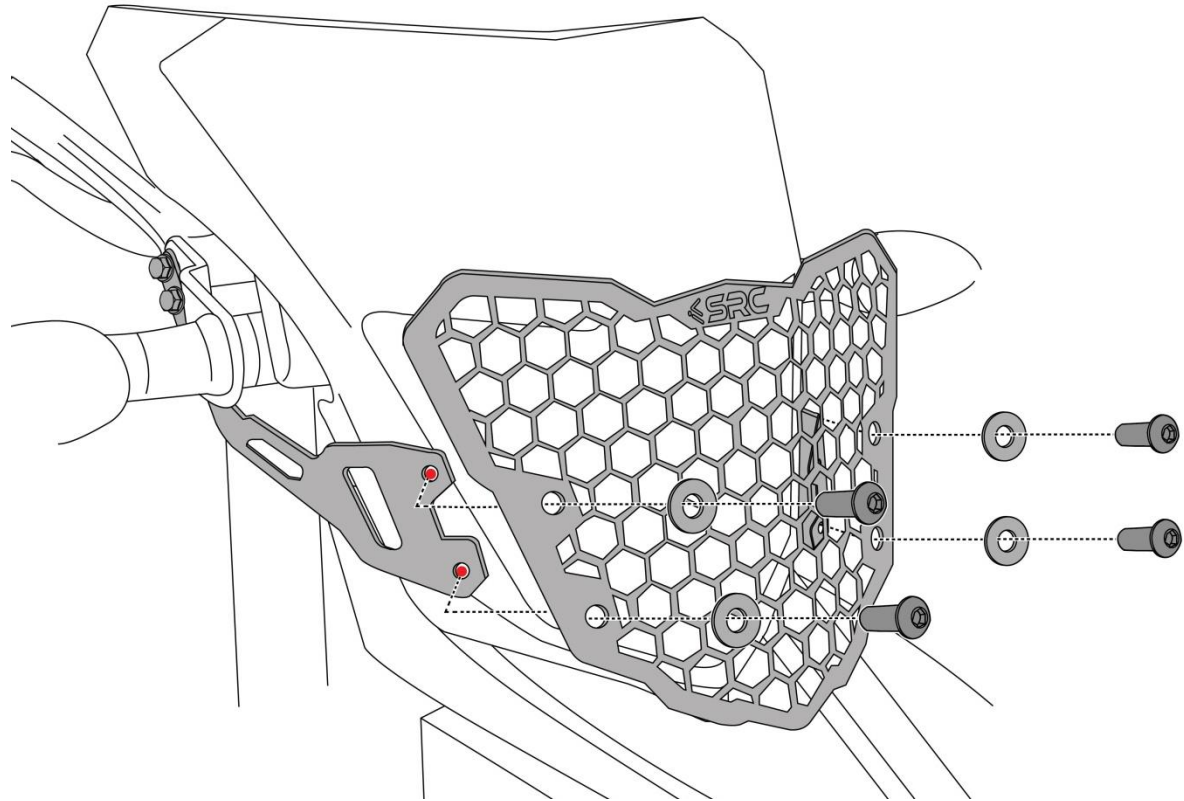

**STEP 4:**

**Ensure Orientation, Mounting Symmetry of the Head Light Guard from the front side and tighten the fasteners to torque as specified in the BOM table**

**The Head Light Guard “As is final Mounted Condition”**



## General Instructions

1. We request you to pay attention to the Mounting Instructions in this document and follow the step-by-step procedures.
2. This Mounting Instruction manual is a “Do It Yourself” (DIY) fitment manual of the Accessory part to the Vehicle. We have prepared this based on our experience and knowledge, related to the Vehicle, Part and its functional aspects.
3. SRC cannot guarantee the interchangeability of the parts to any other manufacturer’s accessory part. It is advised to the User, to inspect and ensure the original state of all other Vehicle parts.
4. We request you to bear in mind, that the Installed part can change the driving behaviour and/or the stability during driving or any other dynamic conditions.
5. If you have the appropriate tools and another person to assist you in the mounting, it will help.
6. After Completion of the Mounting and before taking on a First ride, Ensure and Check all functions of the Vehicle. It is always advised to check loosening of the fasteners after the first 50 kilo meters of ride and at regular intervals.
7. To the maximum extent possible, our design use the current Mounting/Fitment of the Original Equipment, so that Installation of these accessories will not affect the Payload or Function of the Vehicle or the Part on which it is mounted to protect it
8. If any additional modifications are to be done, prior to the fitment of the accessories, it will be explicitly specified in the instruction sheets