

Scope of Supply/Bill of Material & Mounting Drawings

Part Number: Y-T700-09-01-AL / Y-T700-09-02

Part Description: Engine Guard– YAMAHA TENERE 700

Applicable to Finished colour versions of Silver and Black

Installation / Parts List / Bill of Material for Mounting

NO.	Description	Quantity	Torque * (N-M)	Remarks **	Chacklist
1	ENGING GUARD	1			
2	Bracket	1			
3	Taper Ring M6	4			
4	Screw M8x30	4			
5	Screw M6x15	4			
6	Washer M8	4			
SRC Design uses Metric System of Measurement and all dimensions in Millimeters					
* Recommended to use the Torque specified in the table					
** Denotes Usage of Liquid Thread Locker in specified Locations					

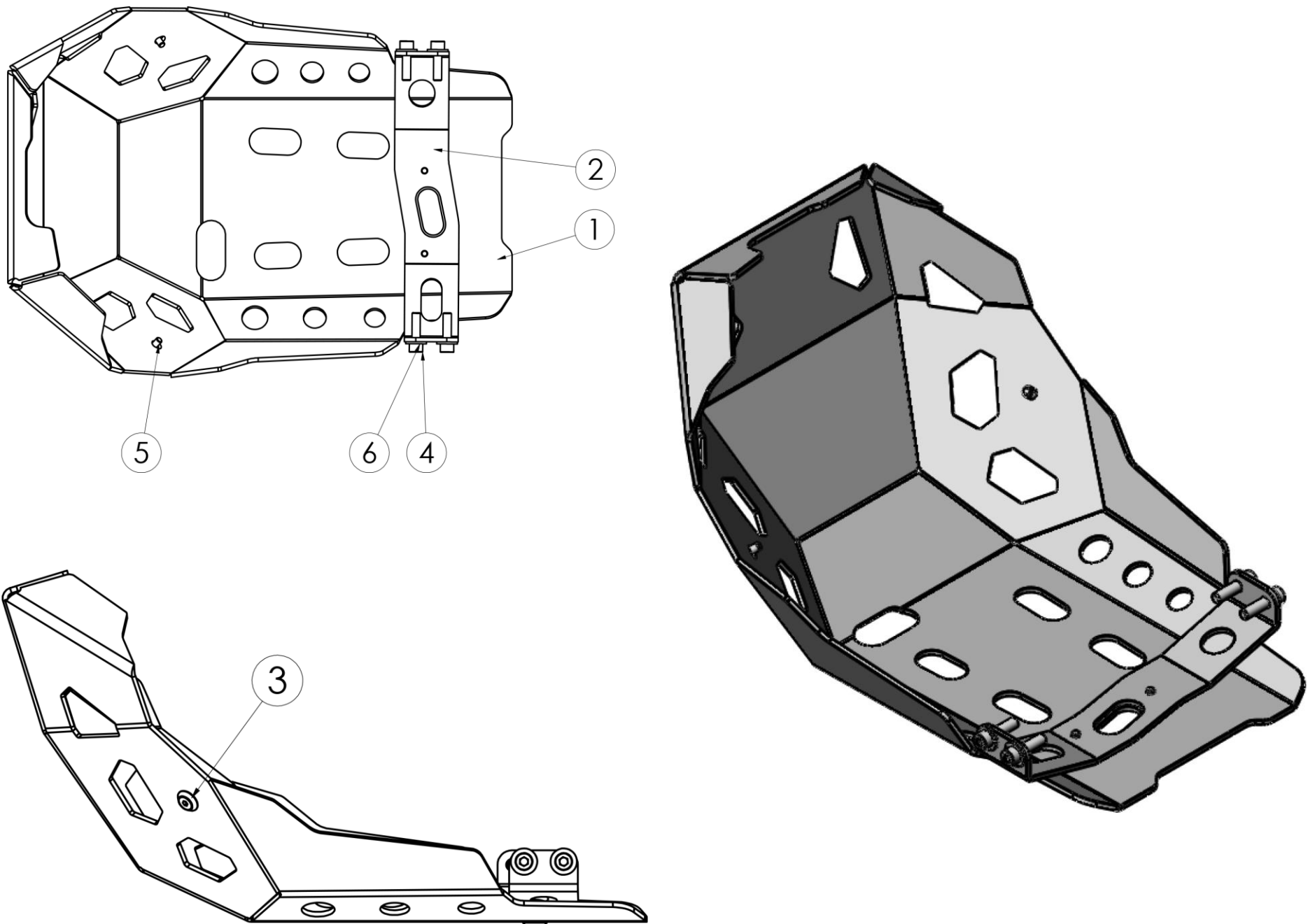

MOUNTING DRAWINGS

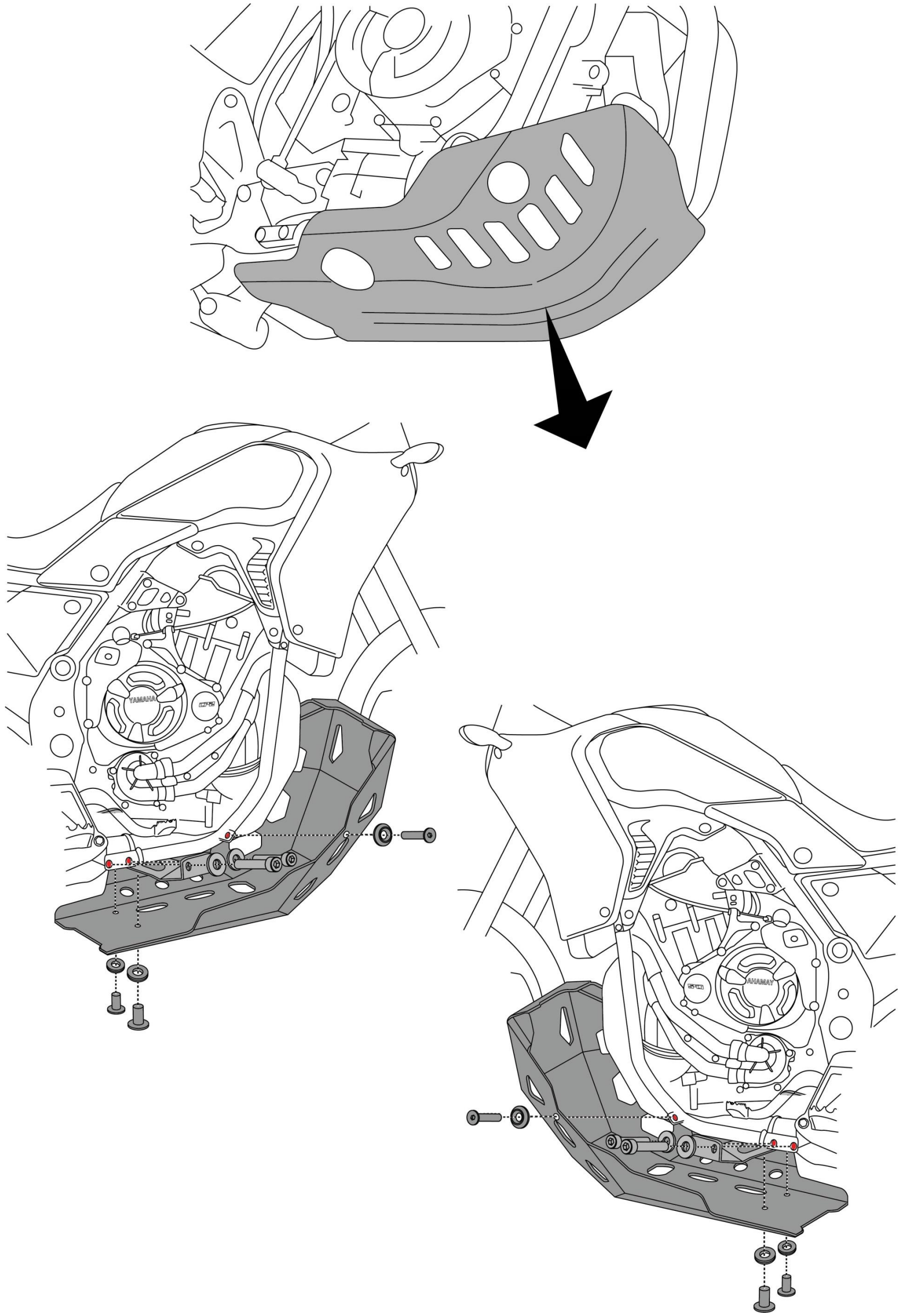

Mounting Instructions

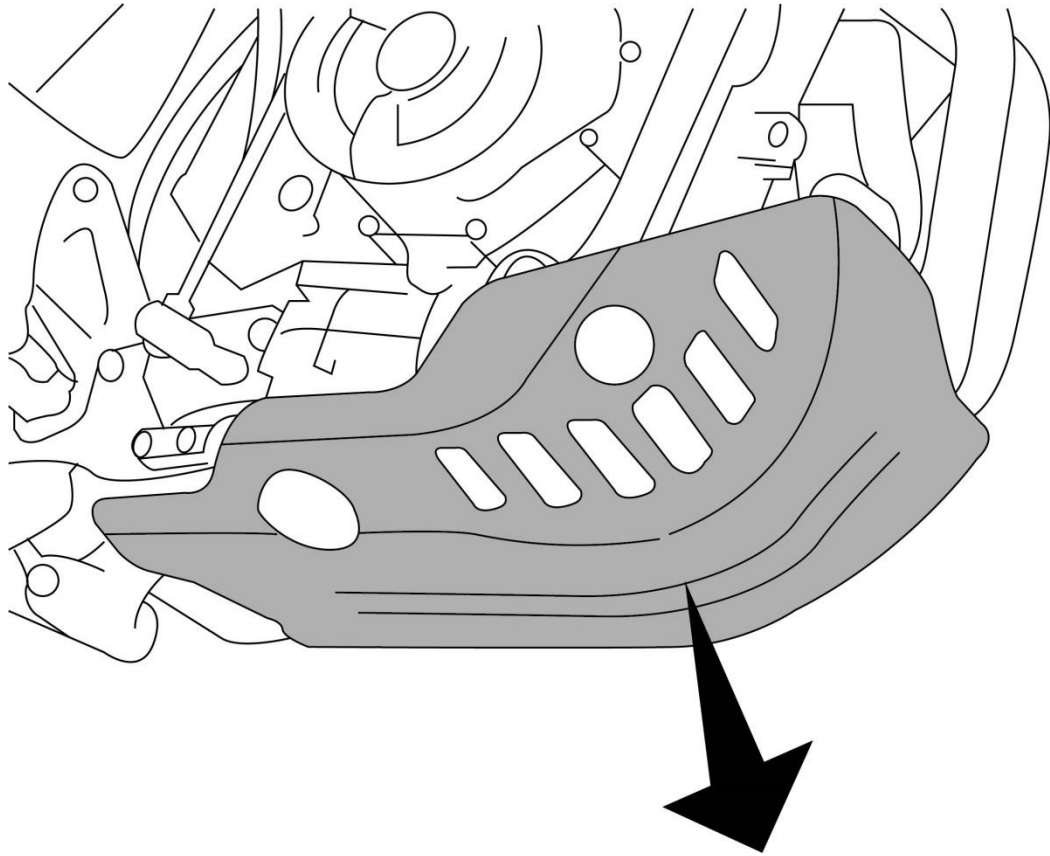

Step 1:

Remove the Cover already installed in the Motorbike. This will allow access to the Mounting Holes for fitment of SRC Engine Guard

Step 2:

Mounting of Rear End Bracket (2)
Orient the Rear End Bracket, as shown, through the holes as shown, and secure the threads, using the Screw M8x30 (4) 2 off, and the washer M8 (6) 2 off, and secure the threads in the Motobike.

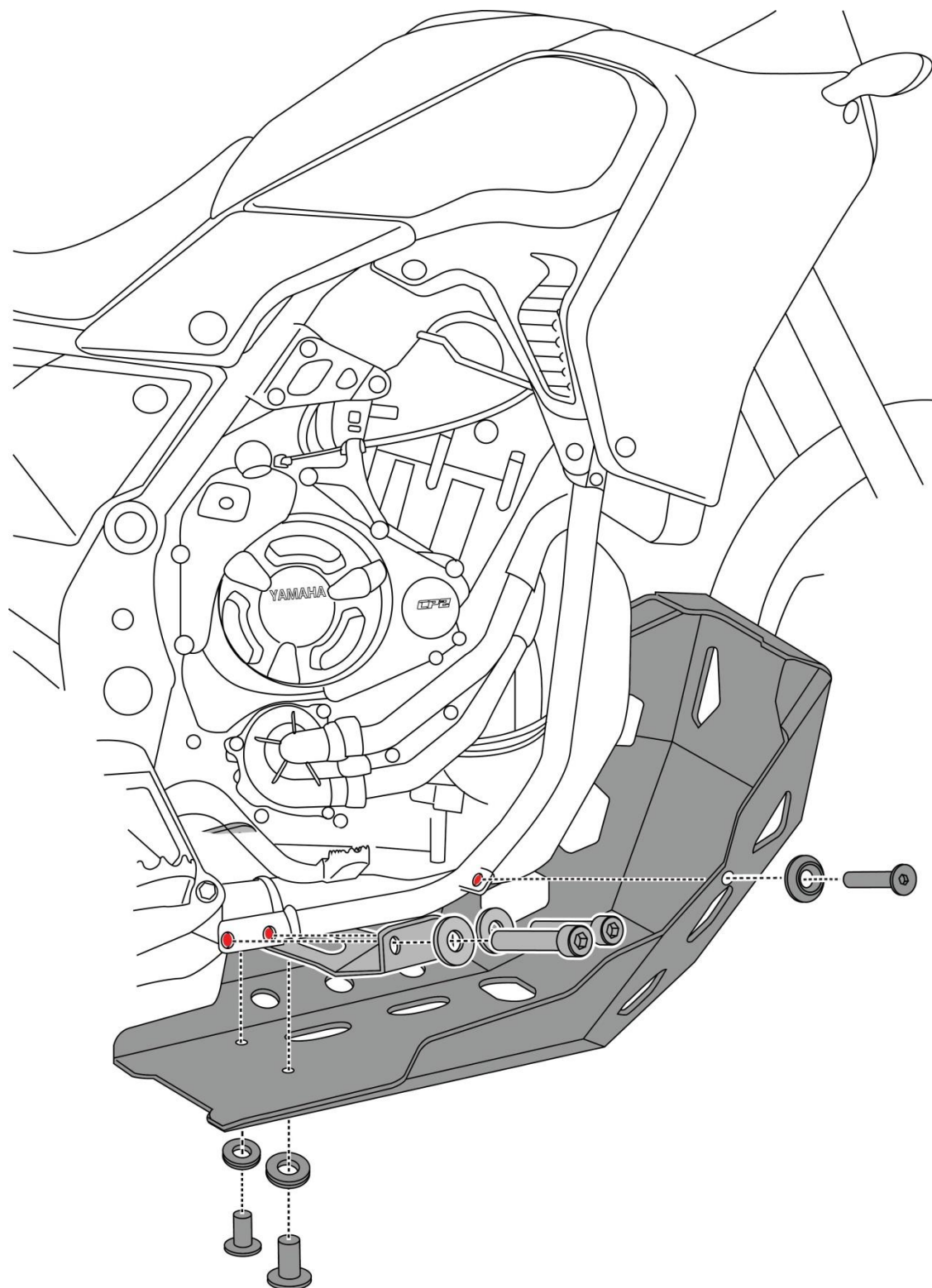

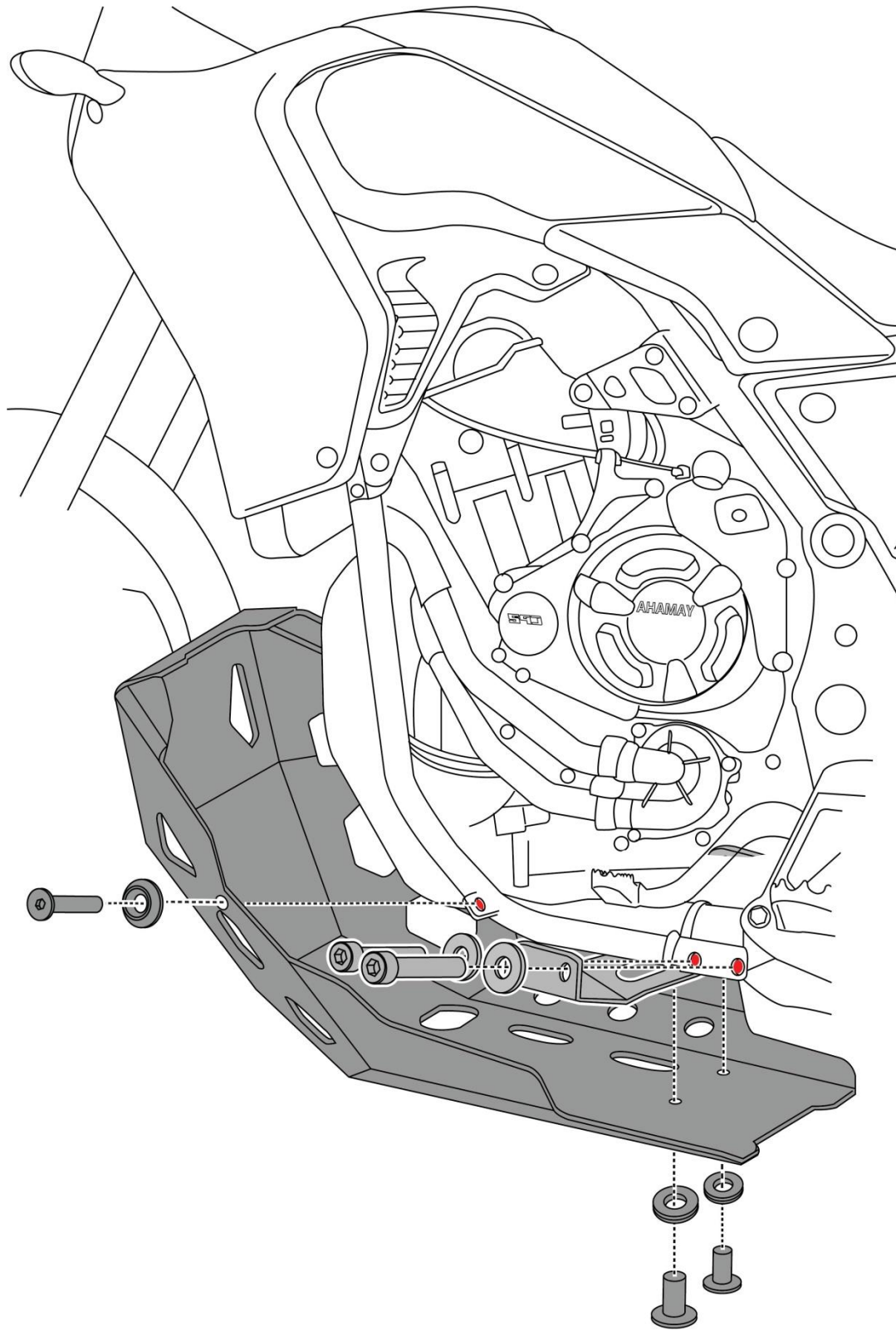

Step 3:

Repeat the Step 2 similarly for mounting the Bracket (2) from the Right-hand side, as shown.



General Instructions

1. We request you to pay attention to the Mounting Instructions in this document and follow the step-by-step procedures.
2. This Mounting Instruction manual is a “Do It Yourself” (DIY) fitment manual of the Accessory part to the Vehicle. We have prepared this based on our experience and knowledge, related to the Vehicle, Part and its functional aspects.
3. SRC cannot guarantee the interchangeability of the parts to any other manufacturer’s accessory part. It is advised to the User, to inspect and ensure the original state of all other Vehicle parts.
4. We request you to bear in mind, that the Installed part can change the driving behaviour and/or the stability during driving or any other dynamic conditions.
5. If you have the appropriate tools and another person to assist you in the mounting, it will help.
6. After Completion of the Mounting and before taking on a First ride, Ensure and Check all functions of the Vehicle. It is always advised to check loosening of the fasteners after the first 50 kilo meters of ride and at regular intervals.
7. To the maximum extent possible, our design use the current Mounting/Fitment of the Original Equipment, so that Installation of these accessories will not affect the Payload or Function of the Vehicle or the Part on which it is mounted to protect it
8. If any additional modifications are to be done, prior to the fitment of the accessories, it will be explicitly specified in the instruction sheets