

## Scope of Supply/Bill of Material & Mounting Drawings

Part Number: Y-T700-17-01-SL - Y-T700-17-01  
 Part Description: Crash Bar YAMAHA TENERE700  
 Applicable to both Stainless Steel Versions

### Installation / Parts List / Bill of Material for Mounting

NO.	Description	Quantity	Torque*(N-M)	Remarks **	Chacklist
1	Crash Bar RH	1			
2	Crash Bar LH	1			
3	Lower Crash Bar RH	1			
4	Lower Crash Bar LH	1			
5	Upper Bracket	1			
6	Lower Bracket	1			
7	Bracket RH	1			
8	Bracket LH	1			
9	Pin pipe upper	2			
10	Pin pipe	1			
11	Ring Taper M8	4			
12	Slider Guards	4			
13	End cap	2			
14	Socket head cap sc rew M8x15	2	23	Use Liquid Thread Locker	
15	Socket head cap sc rew M8x55	2	23	Use Liquid Thread Locker	
16	Socket head cap sc rew M10x30	2	46	Use Liquid Thread Locker	
17	Socket but ton head sc rew M6x15	6	9.6	Use Liquid Thread Locker	
18	Socket countersunk head cap sc rew M8x30	4	23	Use Liquid Thread Locker	
19	Socket head cap sc rew M12x1.25 L55	1	79	Use Liquid Thread Locker	
20	Socket head cap sc rew M12x1.25 L65	1	79	Use Liquid Thread Locker	
21	Nut M8	2			
22	washer M6	6			
23	washer M8	4			

SRC Design uses Metric System of Measurement and all dimensions in Millimeters

\* Recommended to use the Torque specified in the table

\*\* Denotes Usage of Liquid Thread Locker in specified Locations

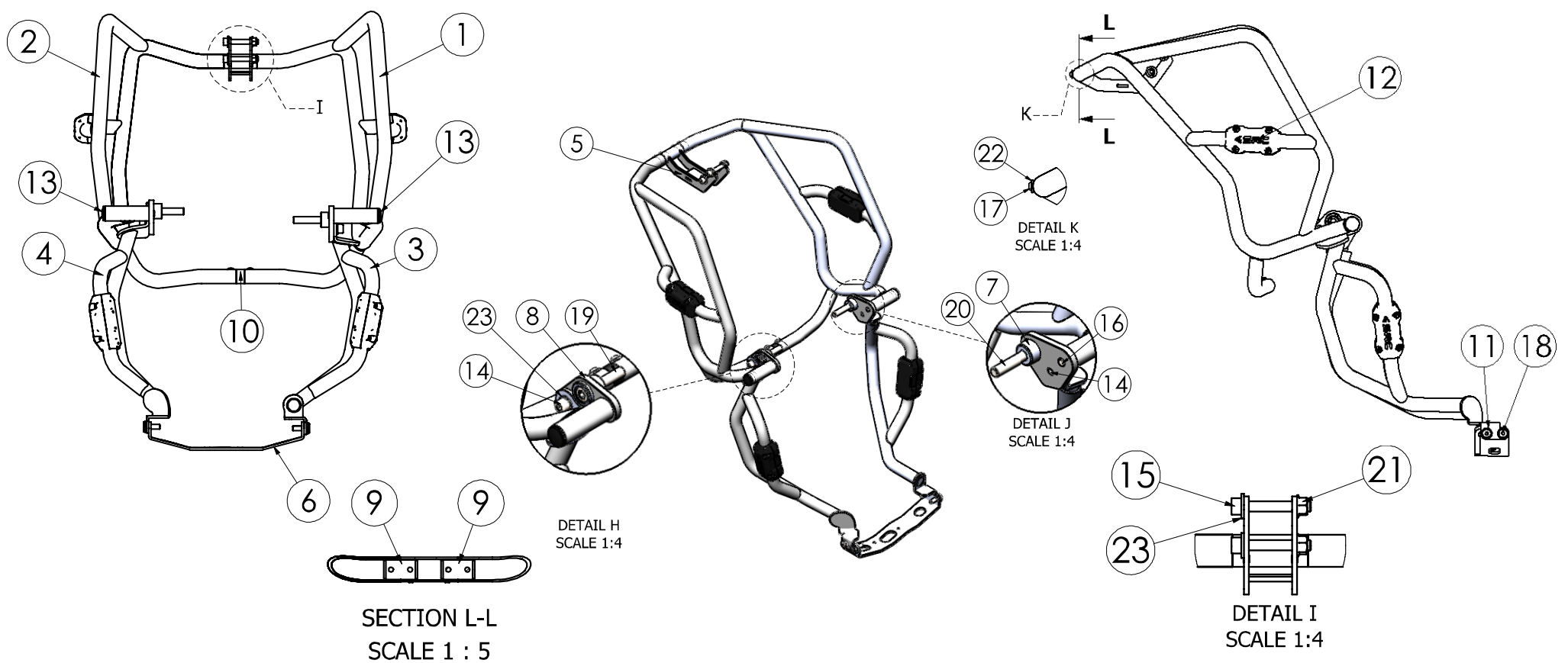

Mounting Drawings

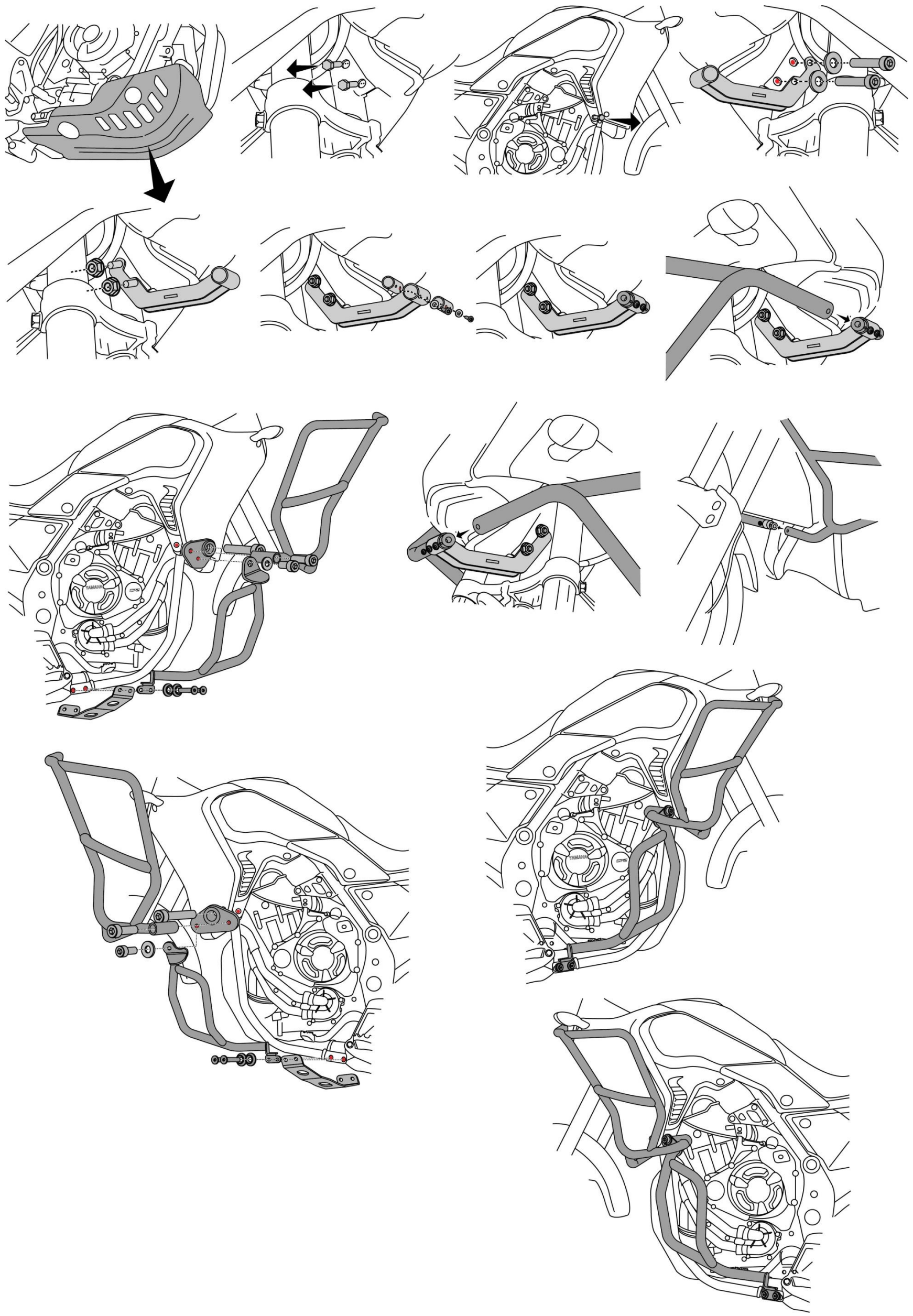

## Mounting Instructions

**Remove the Original Engine Guard installed in the Motorbike.**

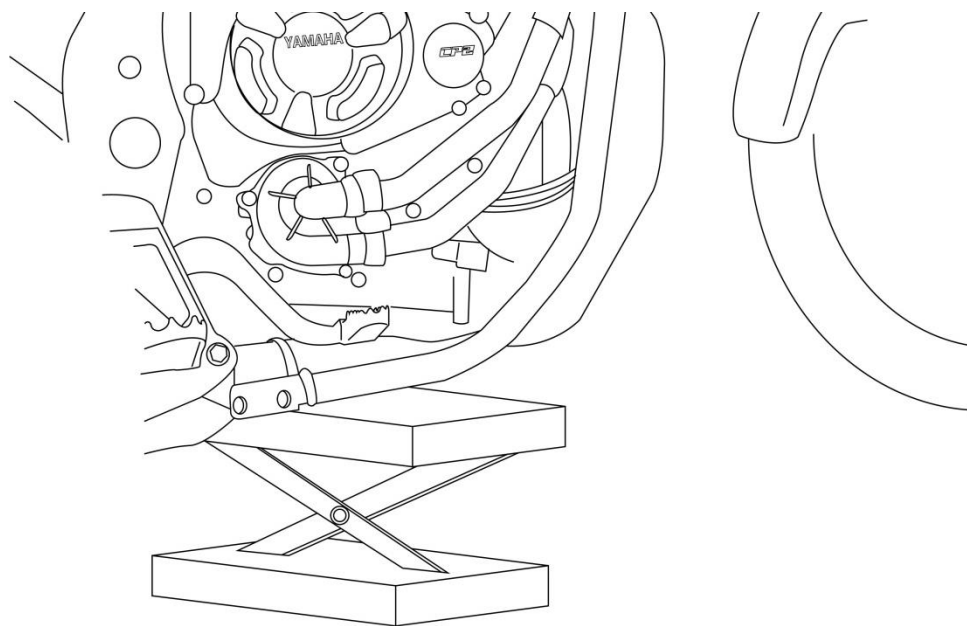
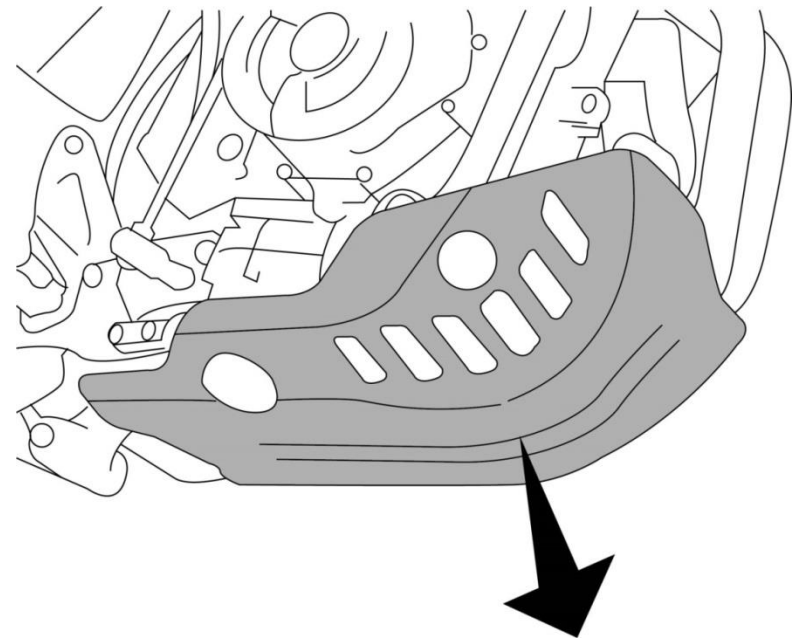

**Before starting to mount, we have to Use the jack to lift the motorbike (as shown)**

**Step 1:**  
**Unscrew the Mounting Original Screw (as shown)**

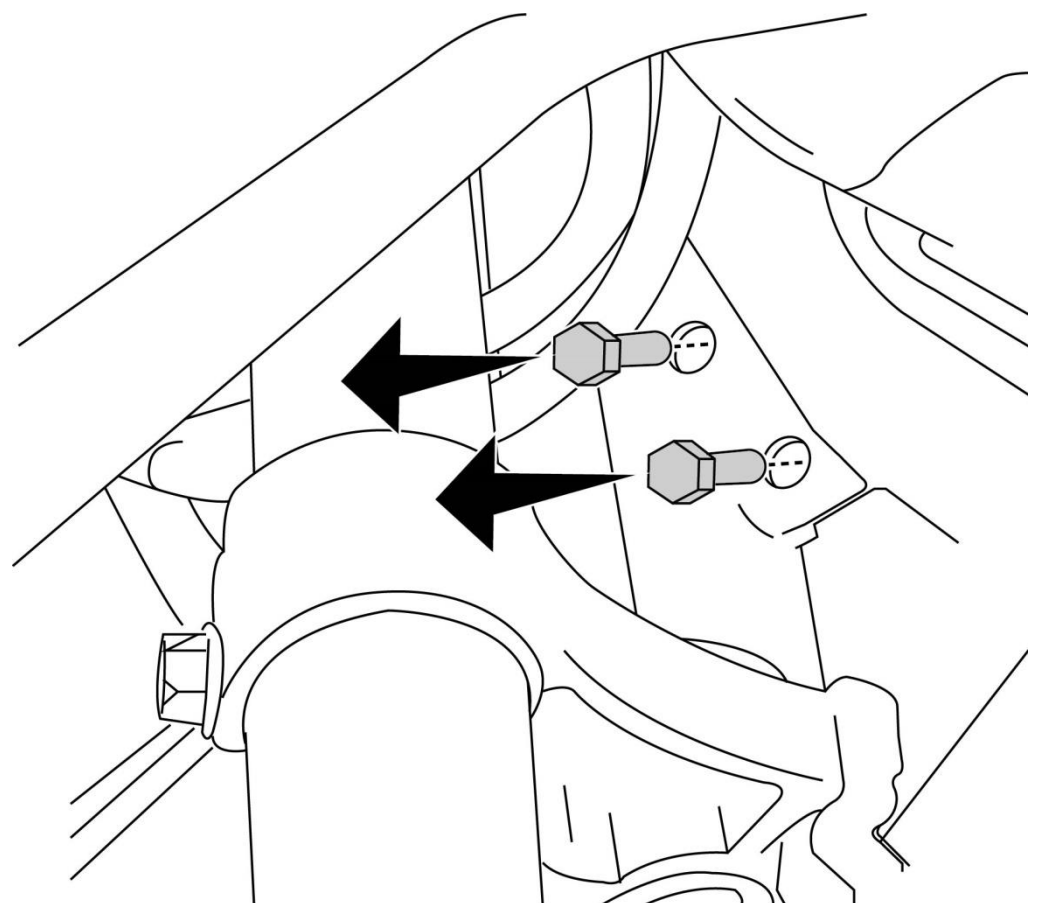

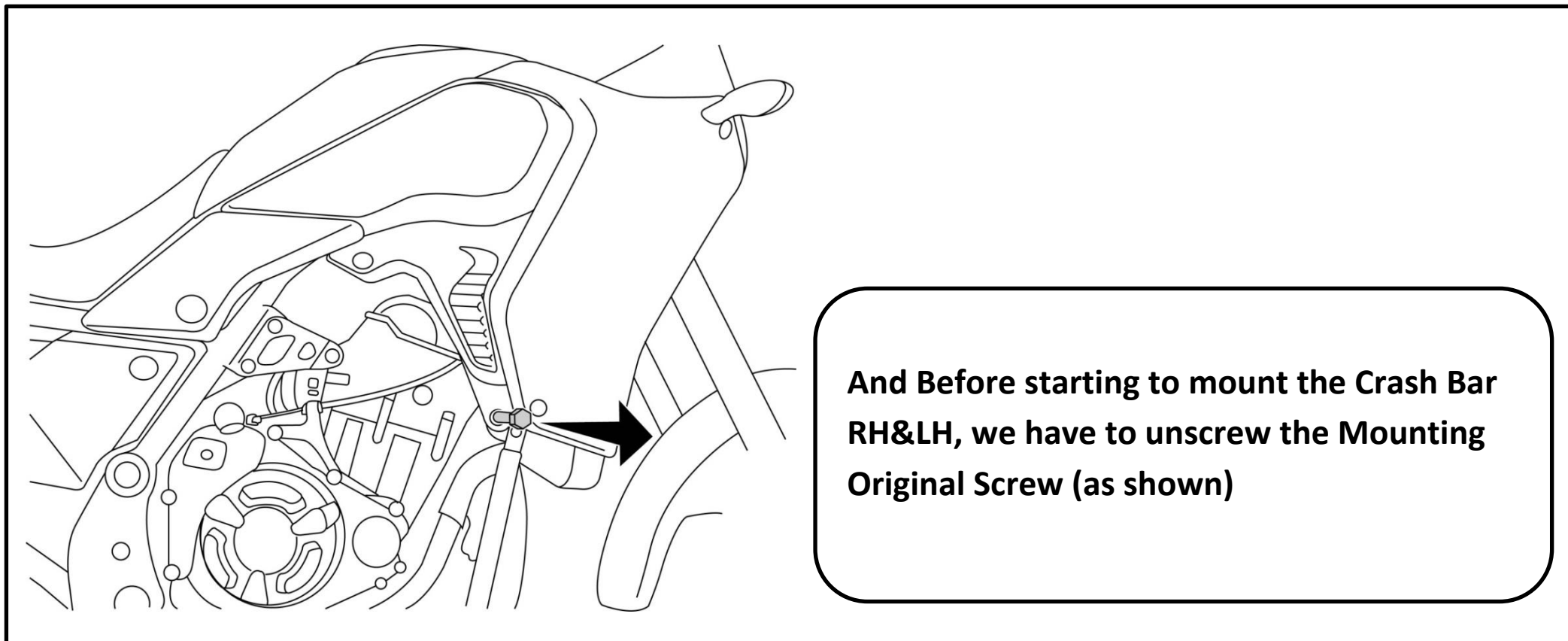

**And Before starting to mount the Crash Bar RH&LH, we have to unscrew the Mounting Original Screw (as shown)**

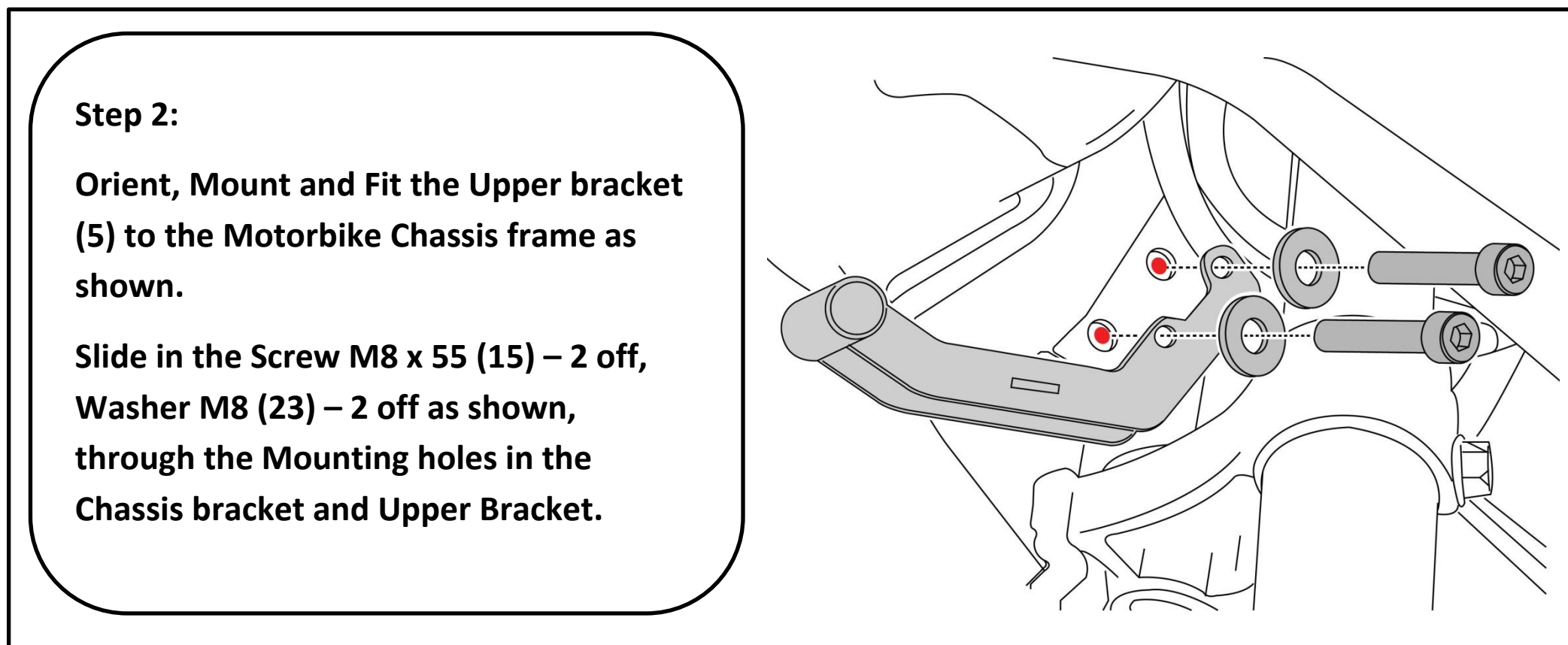

**Step 2:**  
**Orient, Mount and Fit the Upper bracket (5) to the Motorbike Chassis frame as shown.**  
**Slide in the Screw M8 x 55 (15) – 2 off, Washer M8 (23) – 2 off as shown, through the Mounting holes in the Chassis bracket and Upper Bracket.**

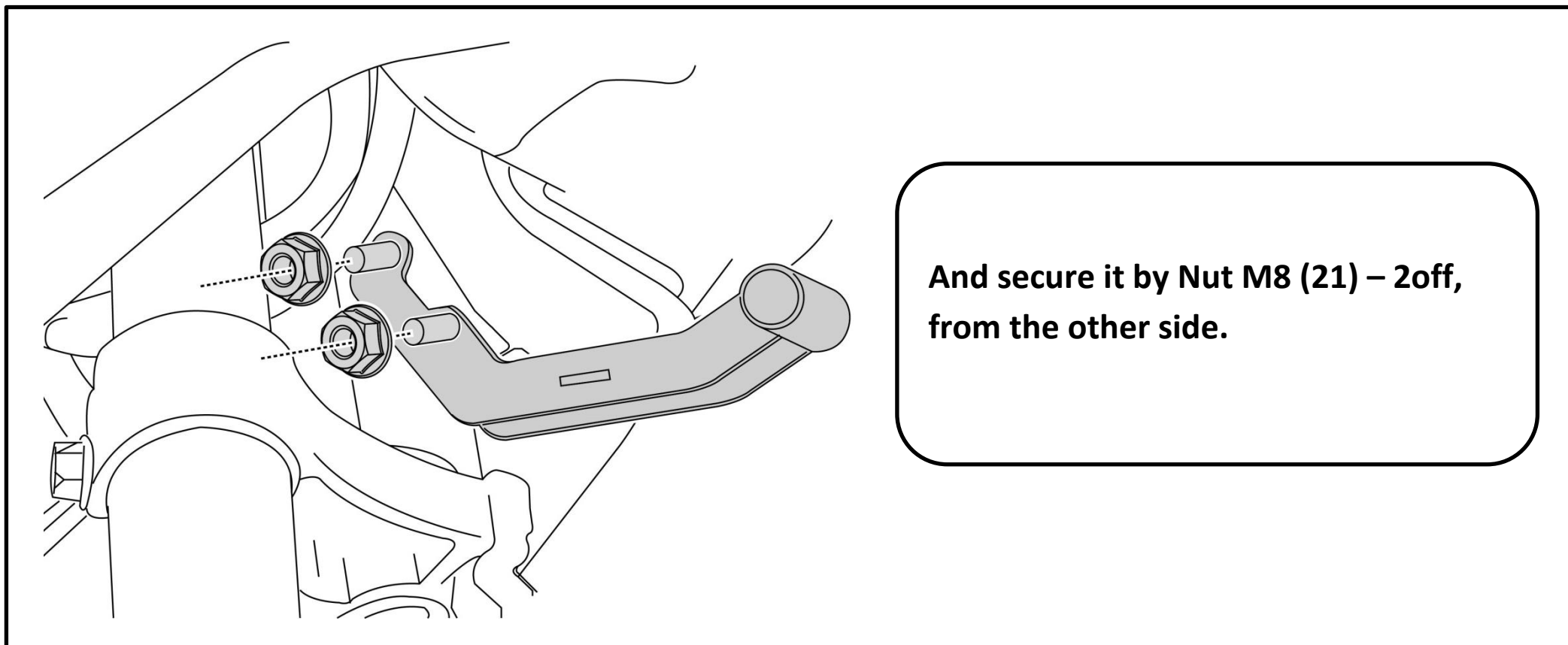

**And secure it by Nut M8 (21) – 2off, from the other side.**

**Step 3:**

**Orient and Align the Pin pipe Upper (9) 2 off, And Slide-in Screw M6x15 (17) – 2 off, and Washer M6 (22) – 2 off, through the Mounting hole in the Upper Bracket and secure the threads in the Pin pipe Upper, as shown.**

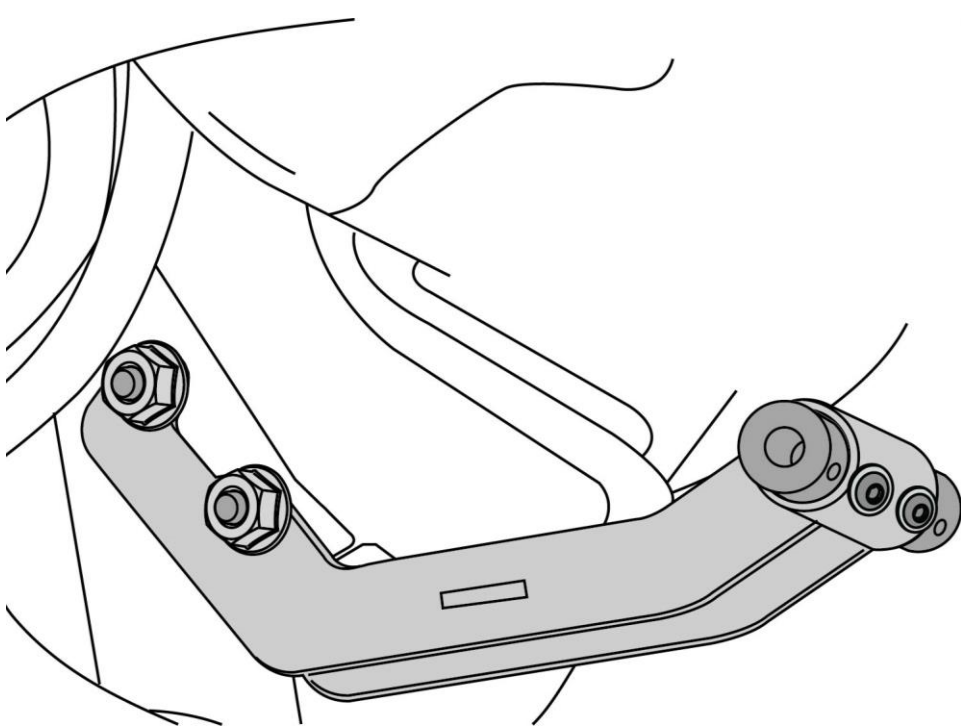
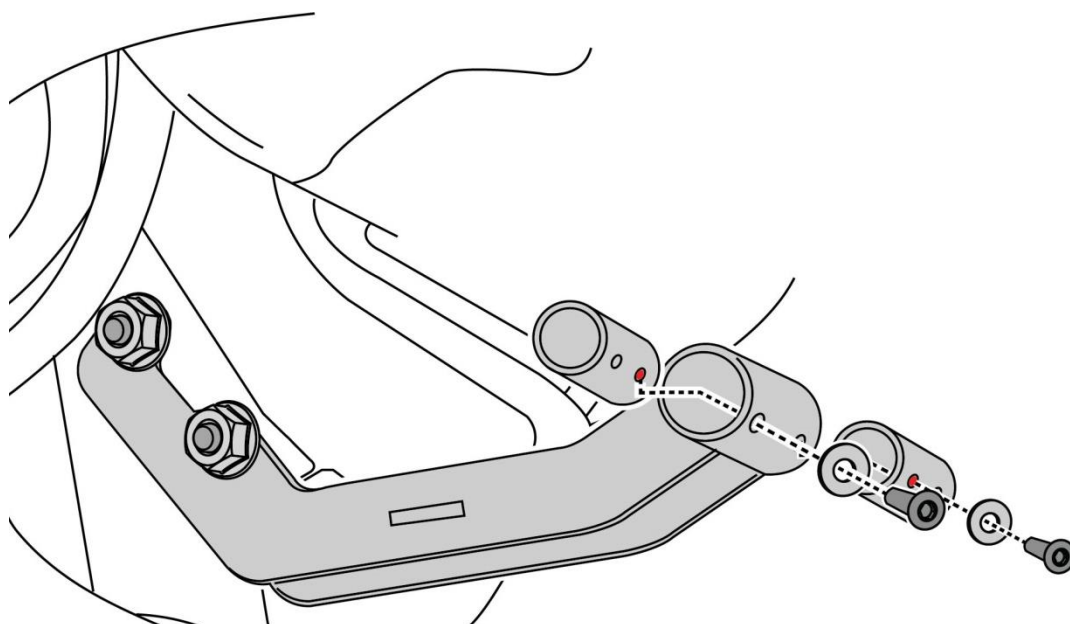

**As is Mounted condition of the mounting the Upper Bracket is as shown.**

**Step 4:**

**Orient the Top End of the Crash Bar RH (1) to the Pin pipe Upper (9) attached to the Upper Bracket (5).**

**And Slide-in Screw M6x15 (17) – 1 off and Washer M6 (22) – 1 off through the Mounting hole in the Crash Bar**

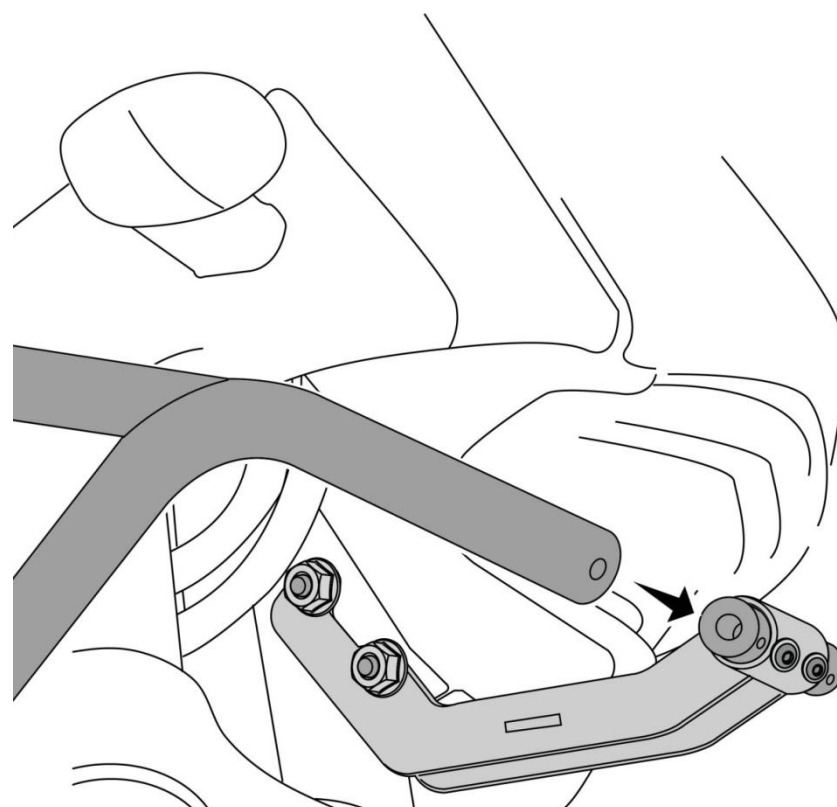

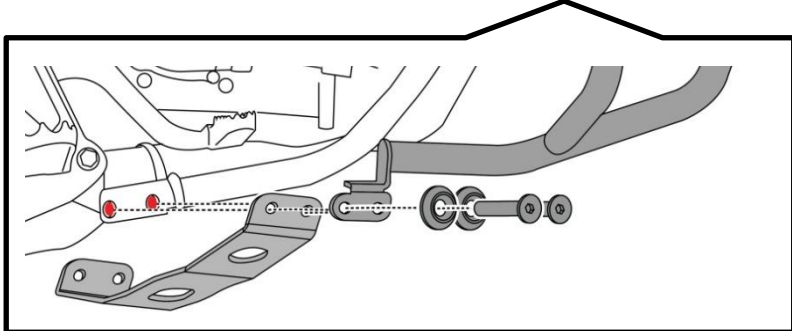
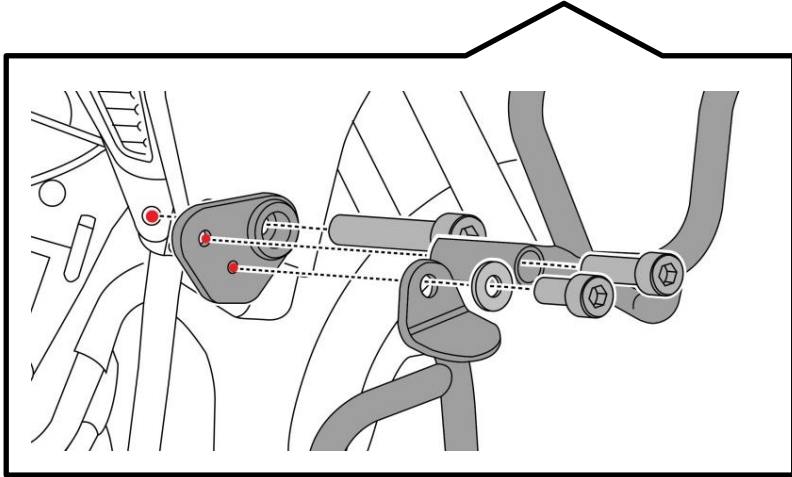
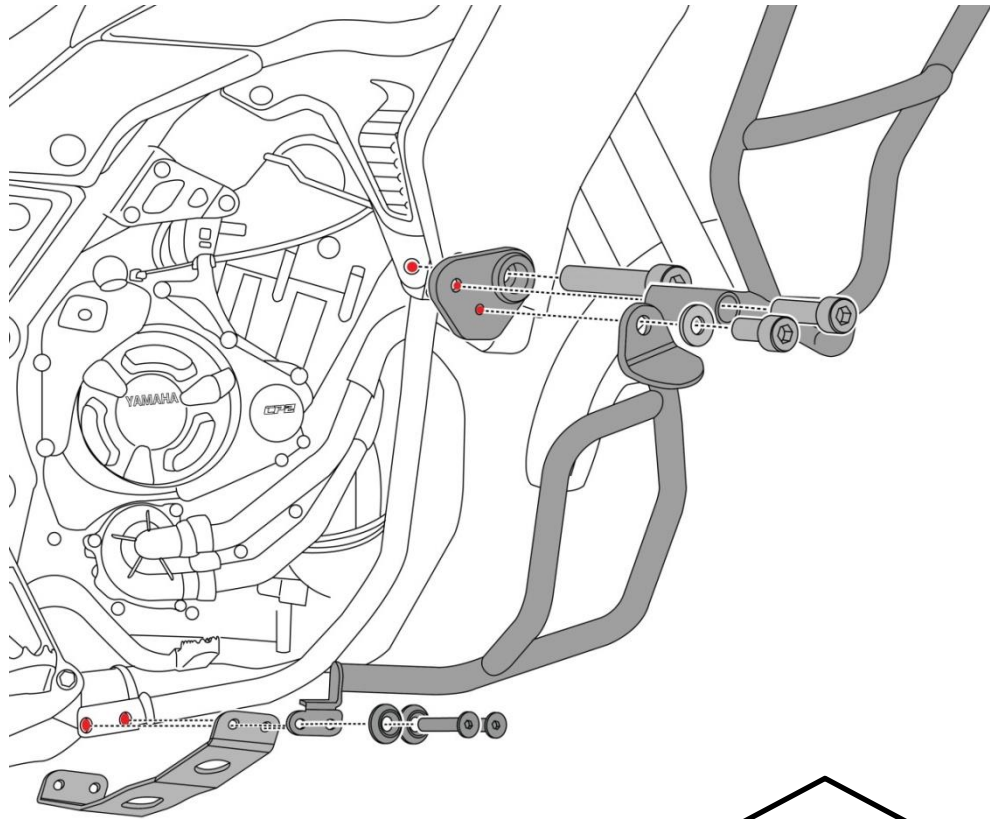

**Step 5:**

**Orient and align the Middle segment of the Crash Bar RH (1) and the Lower Crash bar RH (3) as shown, in-line with the mounting point shown in red colour.**

**Slip-in the Bracket RH (7) – 1 off in-line with the Mounting point pass the Screw M12 x 65 (20) – 1 off, as shown, in-line with the mounting point shown in red colour.**

**Slide-in the Screw M10 x 30 (16) –1 off, the Crash Bar RH (1), the Washer M8 (23) the Screw M8 x 15 (14) –1 off , the Screw M8x30 (18) the Taper Ring M8 (11) the Lower Crash Bar RH (3) and through the Mounting hole in the Bracket RH (7) and the Lower Bracket (6) and secure the threads in the motobike**

**Step 6:**

**Orient and align the Crash Bar LH (2), as shown.**

**Slide-in Screw M6 x 15 (17) – 1 off and Washer M6 (22) – 1 off through the Mounting hole in the Crash Bar and secure the threads in the Pin pipe Upper (9).**

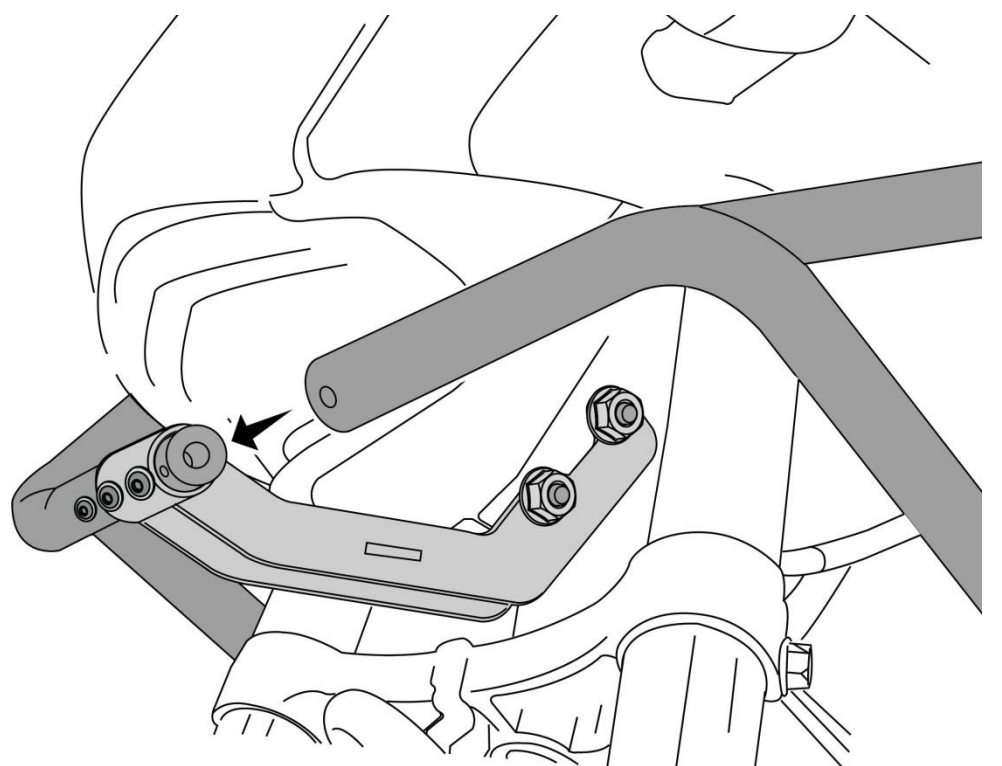

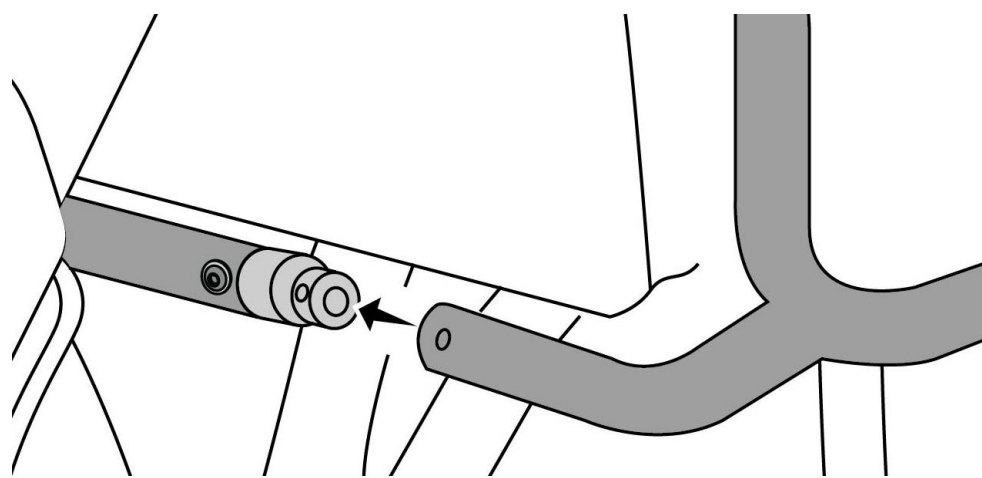

**Step 7:**

Align the Crash Bar LH (2) , as shown, and slide-in Screw M6 x 15 (17) – 1 off and Washer M6 (22) – 1 off and secure the threads in the other end of the Pin-pipe (10).

**Step 8:**

Orient and align the Middle segment of the Crash Bar LH (2) and the Lower Crash bar LH (4) as shown, in-line with the mounting point shown in red colour.

Slip-in the Bracket LH (8 ) – 1 off in-line with the Mounting point pass the Screw M12 x 55 (19) – 1 off, as shown, in-line with the mounting point shown in red colour.

Slide-in the Screw M10 x 30 (16) –1 off, the Crash Bar LH (2) , the Washer M8 (23) the Screw M8 x 15 (14) –1 off , the Screw M8x30 (18) the Taper Ring M8 (11) the Lower Crash Bar RH (3) and through the Mounting hole in the Bracket LH (8) and the Lower Bracket (6) and secure the threads in the motobike.

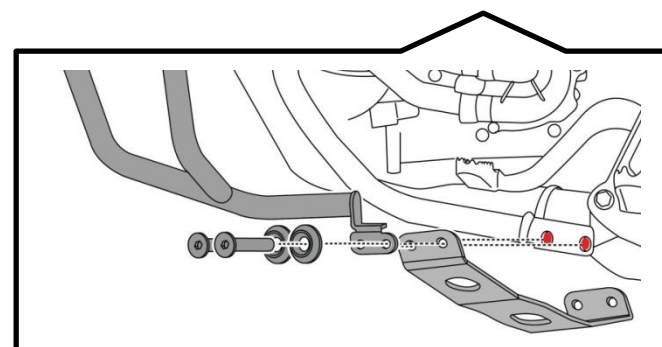
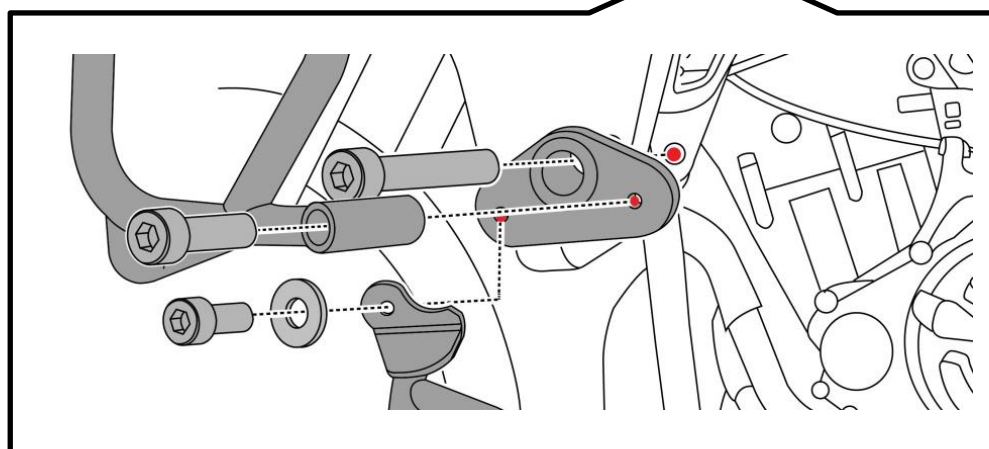
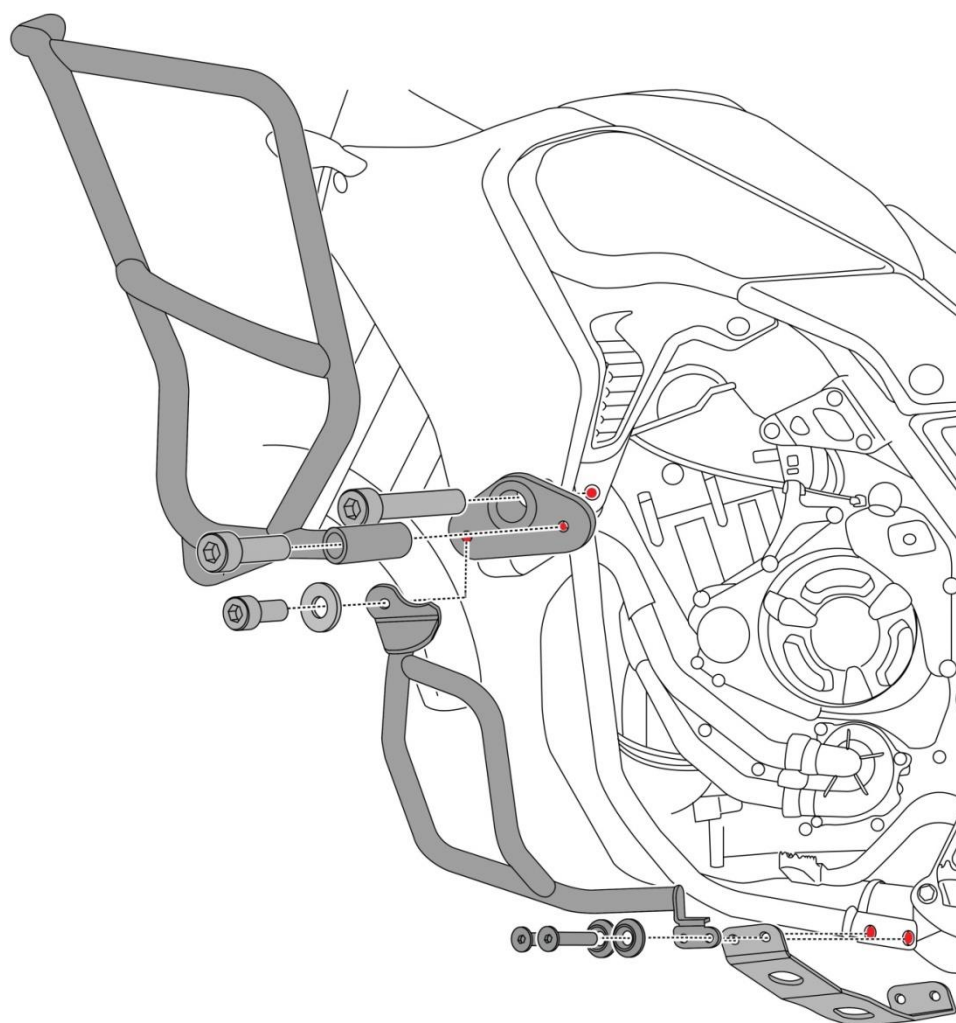

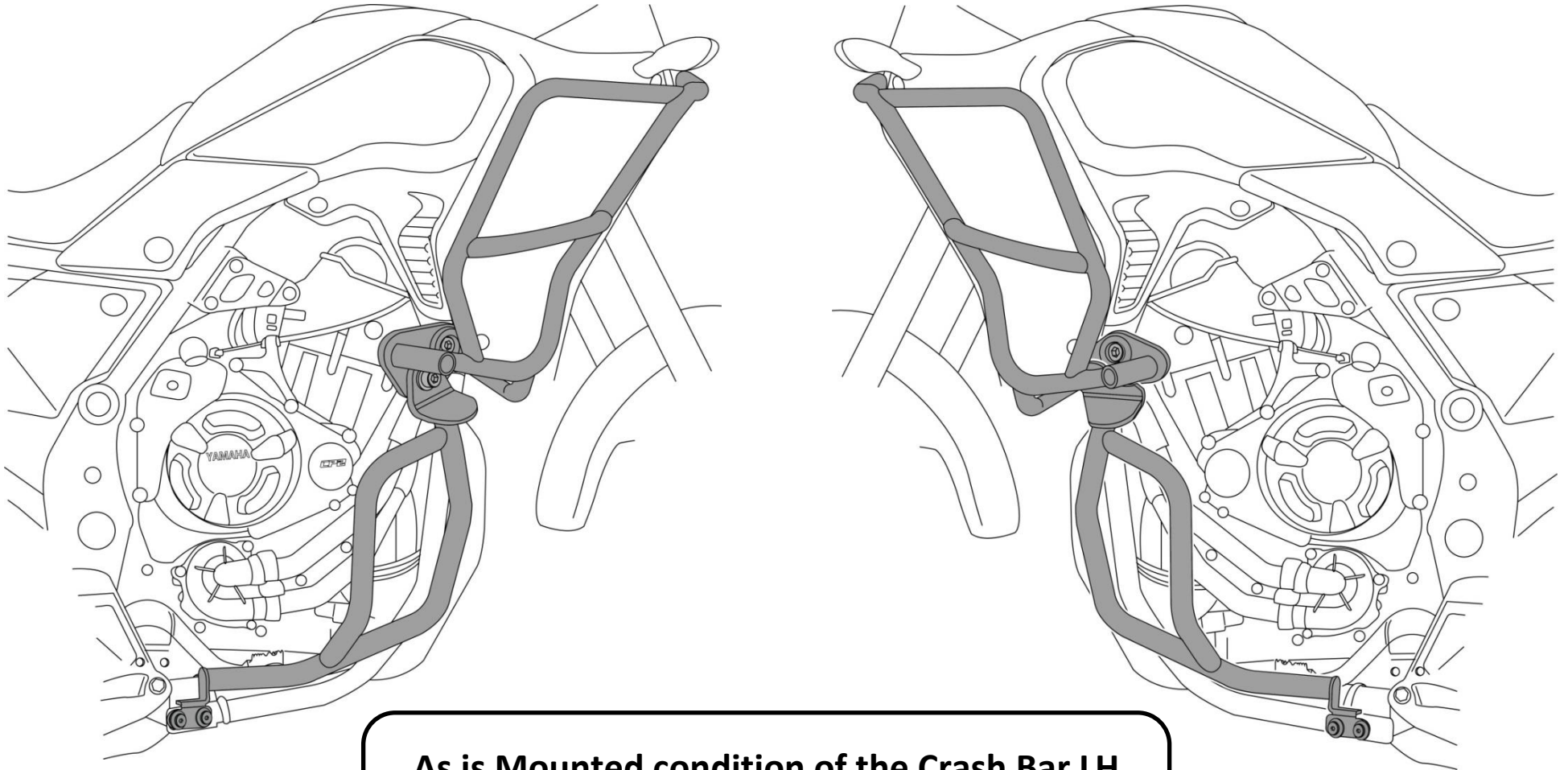

**As is Mounted condition of the Crash Bar LH and RH is as shown.**

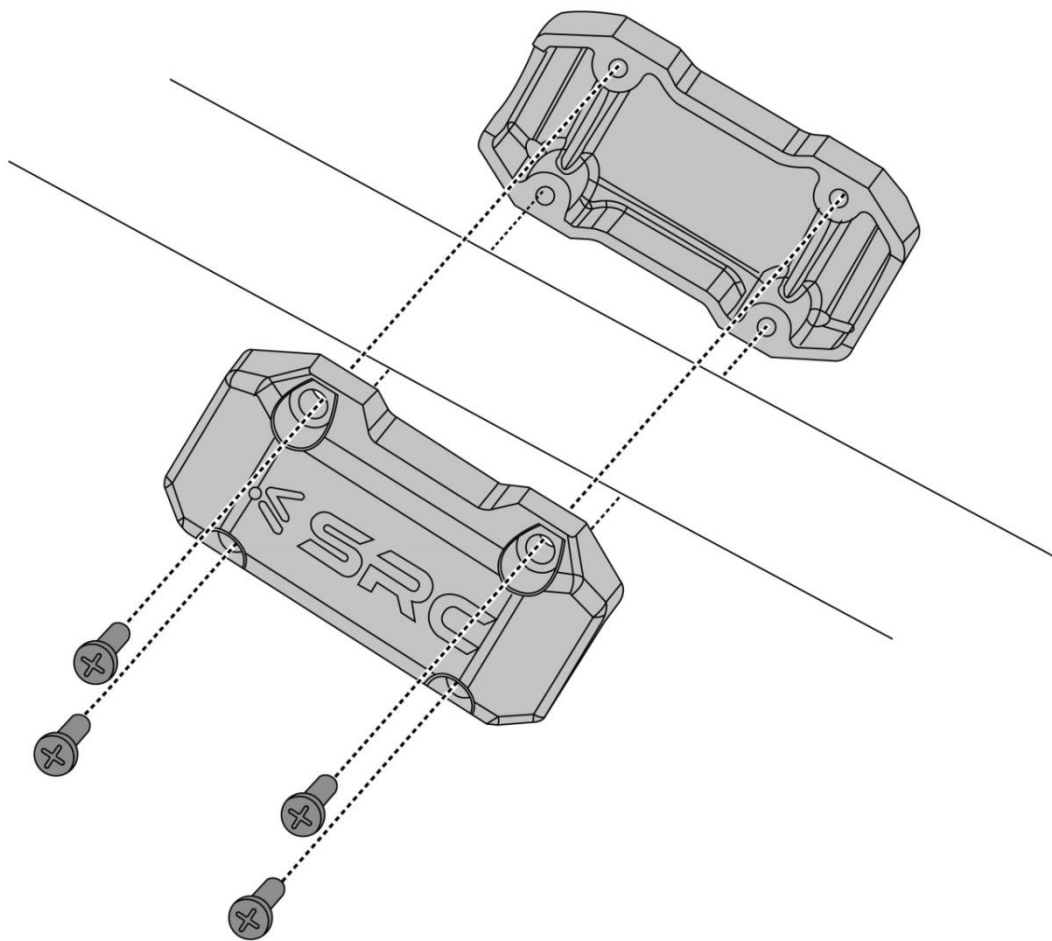

**Step 9:**

**Assemble the Slider Bar on each of the Crash Bar as shown.**

**Use the Slider Bar as the Virtual Orientation and looking from the front side of the Motorbike, make one final Positioning and Alignment of the Crash bars.**

**Ensure mounting symmetry of the Slider Bars visually (it must not be offset or shifted visually when seen from the front side and back side).**





## General Information

1. We request you to pay attention to the Mounting Instructions in this document and follow the step-by-step procedures.
2. This Mounting Instruction manual is a “Do It Yourself” (DIY) fitment manual of the Accessory part to the Vehicle. We have prepared this based on our experience and knowledge, related to the Vehicle, Part and its functional aspects.
3. SRC cannot guarantee the interchangeability of the parts to any other manufacturer’s accessory part. It is advised to the User, to inspect and ensure the original state of all other Vehicle parts.
4. We request you to bear in mind, that the Installed part can change the driving behaviour and/or the stability during driving or any other dynamic conditions.
5. If you have the appropriate tools and another person to assist you in the mounting, it will help.
6. To the maximum extent possible, our design use the current Mounting/Fitment of the Original Equipment, so that Installation of these accessories will not affect the Payload or Function of the Vehicle or the Part on which it is mounted to protect it
7. If any additional modifications are to be done, prior to the fitment of the accessories, it will be explicitly specified in the instruction sheets.